



# HOSHIZAKI

## Service Manual

Modular Crescent Cuber  
Serenity Series

Models

KMS-1122MLJ with SRK-12J/3



[hoshizakiamerica.com](http://hoshizakiamerica.com)

Number: 73223  
Issued: 3-21-2018  
Revised: 3-12-2019

**⚠ WARNING**

Only qualified service technicians should install and service the appliance. To obtain the name and phone number of your local Hoshizaki Certified Service Representative, visit [www.hoshizaki.com](http://www.hoshizaki.com). No service should be undertaken until the technician has thoroughly read this Service Manual. Failure to service and maintain the appliance in accordance with this manual will adversely affect safety, performance, component life, and warranty coverage and may result in costly water damage. Proper installation is the responsibility of the installer. Product failure or property damage due to improper installation is not covered under warranty.

Hoshizaki provides this manual primarily to assist qualified service technicians in the service of the appliance.

Should the reader have any questions or concerns which have not been satisfactorily addressed, please call, send an e-mail message, or write to the Hoshizaki Technical Support Department for assistance.

Phone: 1-800-233-1940; (770) 487-2331

Fax: 1-800-843-1056; (770) 487-3360

E-mail: [techsupport@hoshizaki.com](mailto:techsupport@hoshizaki.com)

**HOSHIZAKI AMERICA, INC.**

618 Highway 74 South

Peachtree City, GA 30269

Attn: Hoshizaki Technical Support Department

Web Site: [www.hoshizaki.com](http://www.hoshizaki.com)

**NOTE:** To expedite assistance, all correspondence/communication **MUST** include the following information:

- Model Number \_\_\_\_\_
- Serial Number \_\_\_\_\_
- Complete and detailed explanation of the problem.

**IMPORTANT**

This manual should be read carefully before the appliance is serviced. Read the warnings and guidelines contained in this manual carefully as they provide essential information for the continued safe use, service, and maintenance of the appliance. Retain this manual for any further reference that may be necessary.

**CONTENTS**

Important Safety Information .....	5
I. Construction and Water/Refrigeration Circuit Diagrams .....	7
A. Construction .....	7
1. Icemaker .....	7
2. Condensing Unit .....	8
B. Water/Refrigeration Circuit Diagram .....	9
II. Sequence of Operation and Service Diagnosis .....	10
A. Sequence of Operation Flow Chart .....	10
1. Operation Flow Chart .....	10
2. Shutdown Flow Chart .....	11
3. Freeze-Time Correction Flow Chart (CB: 2A7664-02) .....	12
B. Service Diagnosis .....	13
C. Freeze-Time Correction Cycle (90 min.) (CB: 2A7664-02) .....	21
D. Control Board Check .....	23
E. Bin Control Check .....	25
F. Float Switch Check and Cleaning .....	26
G. Thermistor Check .....	28
H. Switches .....	29
1. Control Switch .....	29
2. Service Switch .....	29
I. Diagnostic Tables .....	30
J. Freeze-Up Check List .....	34
III. Controls and Adjustments .....	35
A. Control Board Layout .....	36
B. LED Lights and Audible Alarm Safeties .....	37
C. Settings and Adjustments .....	38
1. Default Dip Switch Settings .....	38
2. Harvest Timer (S4 dip switch 1 & 2) .....	39
3. Pump-Out Timer/Harvest Time During Pump-Out (S4 dip switch 3 & 4) .....	39
4. Pump-Out Frequency Control (S4 dip switch 5) .....	40
5. Harvest Pump Time (Harvest Assist Duration) (S4 dip switch 6) .....	40
6. Harvest Pump Time (Harvest Assist)/Freeze-Time Correction (S4 dip switch 7) ...	41
7. Factory Use (S4 dip switch 8) .....	41
8. Freeze Timer (S4 dip switch 9 & 10) .....	42
9. Float Switch Control Selector for Refill (S5 dip switch 1) .....	42
10. Refill Counter (S5 dip switch 2 and 3) .....	43
11. Minimum Harvest Time (S5 dip switch 4) .....	43
12. Anti-Slush (S5 dip switch 5) .....	43

IV. Refrigeration Circuit and Component Service Information.....	44
A. Refrigeration Circuit Service Information .....	44
B. Component Service Information.....	47
V. Maintenance .....	48
VI. Preparing the Appliance for Periods of Non-Use .....	49
VII. Disposal.....	50
VIII. Technical Information.....	51
A. Specification and Performance Data Sheets.....	51
1. KMS-1122MLJ with SRK-12J .....	51
2. KMS-1122MLJ with SRK-12J3.....	52
3. SRK-12J .....	53
4. SRK-12J3 .....	54
B. Wiring Diagrams.....	55
1. Wire Harness Connections.....	55
2. KMS-1122MLJ with SRK-12J.....	56
3. KMS-1122MLJ with SRK-12J3.....	57

---

## Important Safety Information

Throughout this manual, notices appear to bring your attention to situations which could result in death, serious injury, damage to the appliance, or damage to property.

**⚠ WARNING** Indicates a hazardous situation which could result in death or serious injury.

**NOTICE** Indicates a situation which could result in damage to the appliance or property.

**IMPORTANT** Indicates important information about the use and care of the appliance.

### **⚠ WARNING**

The appliance should be destined only to the use for which it has been expressly conceived. Any other use should be considered improper and therefore dangerous. The manufacturer cannot be held responsible for injury or damage resulting from improper, incorrect, and unreasonable use. Failure to service and maintain the appliance in accordance with this manual will adversely affect safety, performance, component life, and warranty coverage and may result in costly water damage.

**To reduce the risk of death, electric shock, serious injury, or fire, follow basic precautions including the following:**

- Only qualified service technicians should install and service the appliance.
- The appliance must be installed in accordance with applicable national, state, and local codes and regulations. Failure to meet these code requirements could result in death, electric shock, serious injury, fire, or damage to the appliance.
- To reduce the risk of electric shock, do not touch the control switch or service switch with damp hands.
- Before servicing the KMS or SRK: Move the KMS control switch to the "OFF" position and turn off the power supply to the SRK condensing unit. Place the KMS disconnect (if applicable) in the "OFF" position. Lockout/Tagout to prevent the power supply from being turned back on inadvertently.
- Do not make any alterations to the appliance. Alterations could result in electric shock, injury, fire, or damage to the appliance.
- The appliance is not intended for use by persons (including children) with reduced physical, sensory, or mental capabilities, or lack of experience and knowledge, unless they have been given supervision or instruction concerning use of the appliance by a person responsible for their safety.
- Children should be properly supervised around the appliance.
- Do not climb, stand, or hang on the appliance or allow children or animals to do so. Serious injury could occur or the appliance could be damaged.
- Do not use combustible spray or place volatile or flammable substances near the appliance. They might catch fire.
- Keep the area around the appliance clean. Dirt, dust, or insects in the appliance could cause harm to individuals or damage to the appliance.

## **⚠ WARNING, continued**

### **For KMS**

- Risk of electric shock. Control switch in "OFF" position does not de-energize all loads.
- Power supply and ground connection are supplied from the SRK remote condensing unit via the wire harness provided. Do not connect the wire harness leads to an external power source.
- Wire harness routing (conduit) and disconnect (if required) must meet national, state, and local electrical code requirements. Failure to meet these code requirements could result in death, electric shock, serious injury, fire, or damage to the appliance.
- **THE ICEMAKER MUST BE GROUNDED.** Failure to properly ground the icemaker could result in death, serious injury, or damage to the appliance.

### **For SRK**

- Electrical connection must be hard-wired and must meet national, state, and local electrical code requirements. Failure to meet these code requirements could result in death, electric shock, serious injury, fire, or damage to the appliance.
- The remote condensing unit requires an independent power supply of proper capacity. See the nameplate for electrical specifications. Failure to use an independent power supply of proper capacity can result in a tripped breaker, blown fuses, damage to existing wiring, or component failure. This could lead to heat generation or fire.
- **THE REMOTE CONDENSING UNIT MUST BE GROUNDED.** Failure to properly ground the remote condensing unit could result in death, serious injury, or damage to the appliance.

## ***NOTICE***

- Follow the instructions in this manual carefully to reduce the risk of costly water damage.
- In areas where water damage is a concern, install in a contained area with a floor drain.
- Install the appliance in a location that stays above freezing. Normal operating ambient temperature must be within 45°F to 100°F (7°C to 38°C).
- Do not leave the appliance on during extended periods of non-use, extended absences, or in sub-freezing temperatures. To properly prepare the appliance for these occasions, follow the instructions in "VI. Preparing the Appliance for Periods of Non-Use."
- Do not place objects on top of the appliance.
- The dispenser unit/ice storage bin is for ice use only. Do not store anything else in the dispenser unit/ice storage bin.

# I. Construction and Water/Refrigeration Circuit Diagrams

## A. Construction

### 1. Icemaker

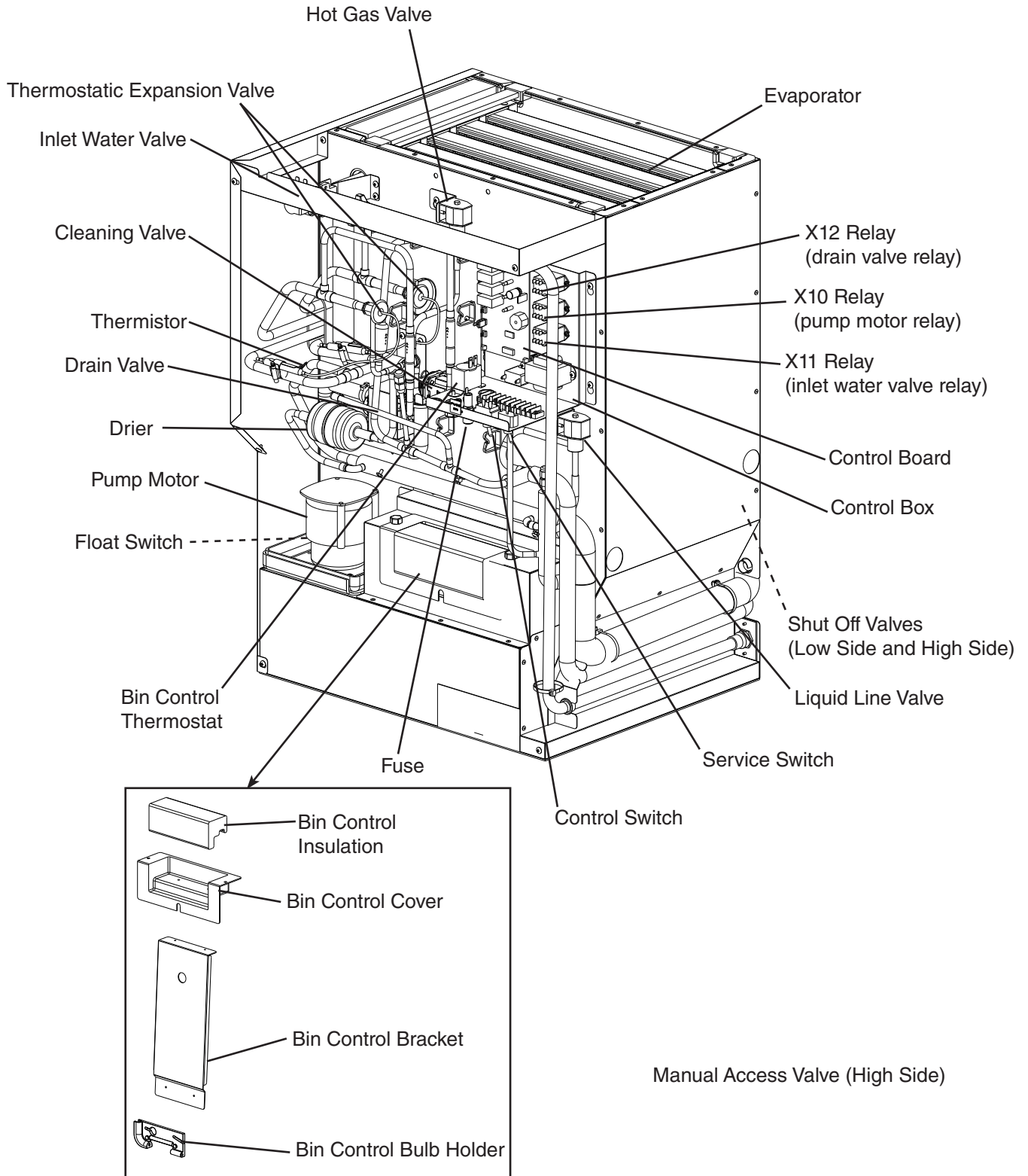

## 2. Condensing Unit

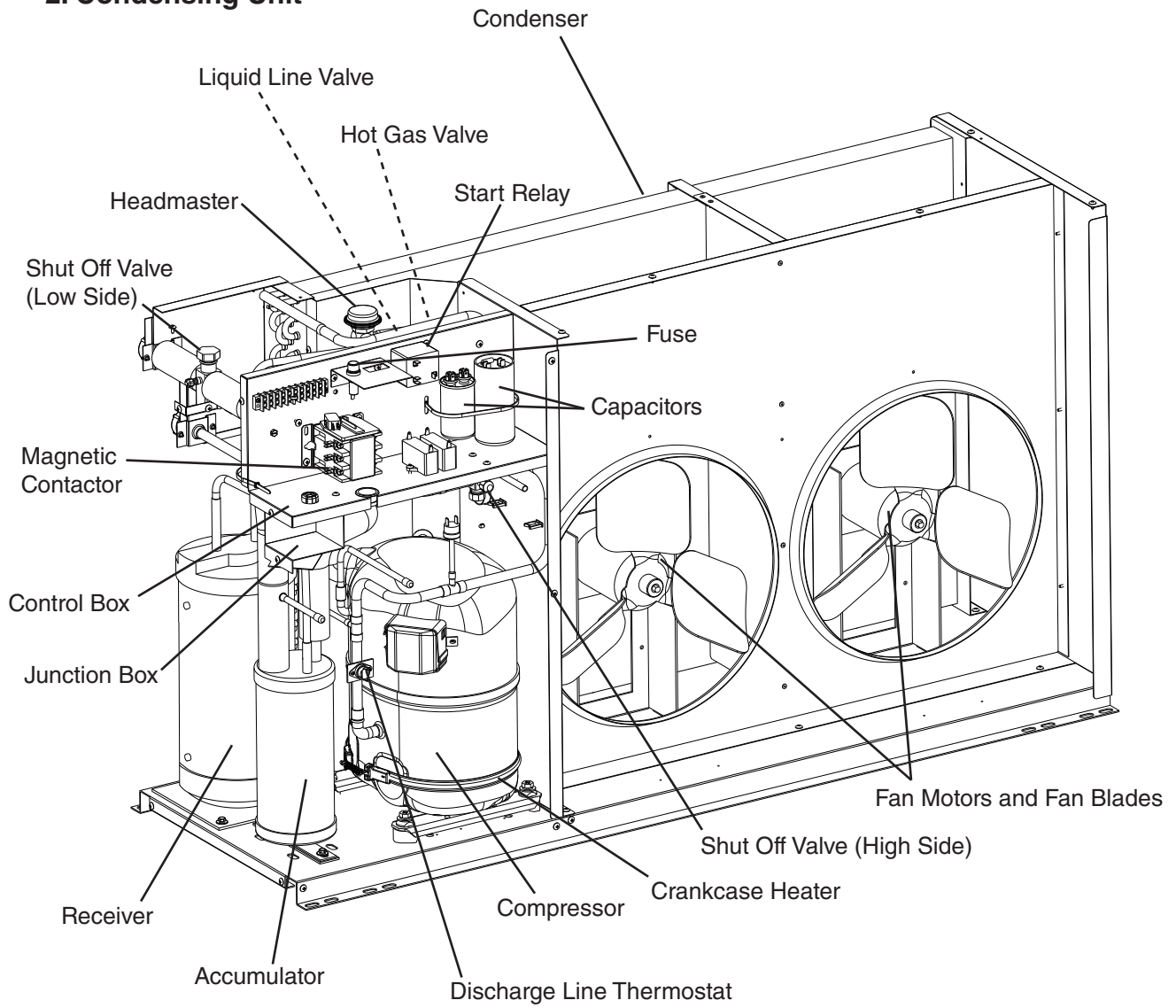

Model Shown: SRK-12J



## B. Water/Refrigeration Circuit Diagram

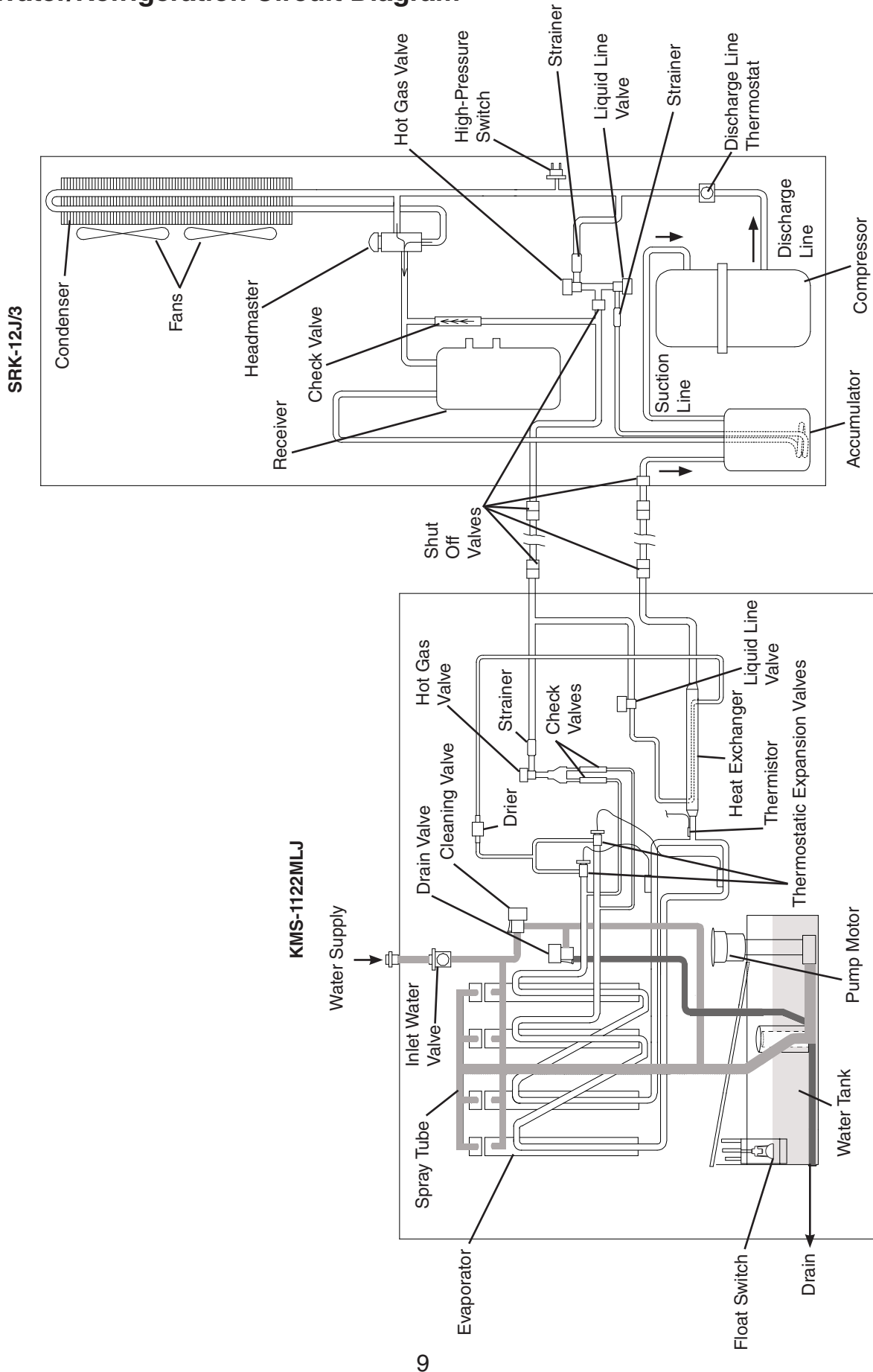

## II. Sequence of Operation and Service Diagnosis

### A. Sequence of Operation Flow Chart

#### 1. Operation Flow Chart

### Operation Flow Chart

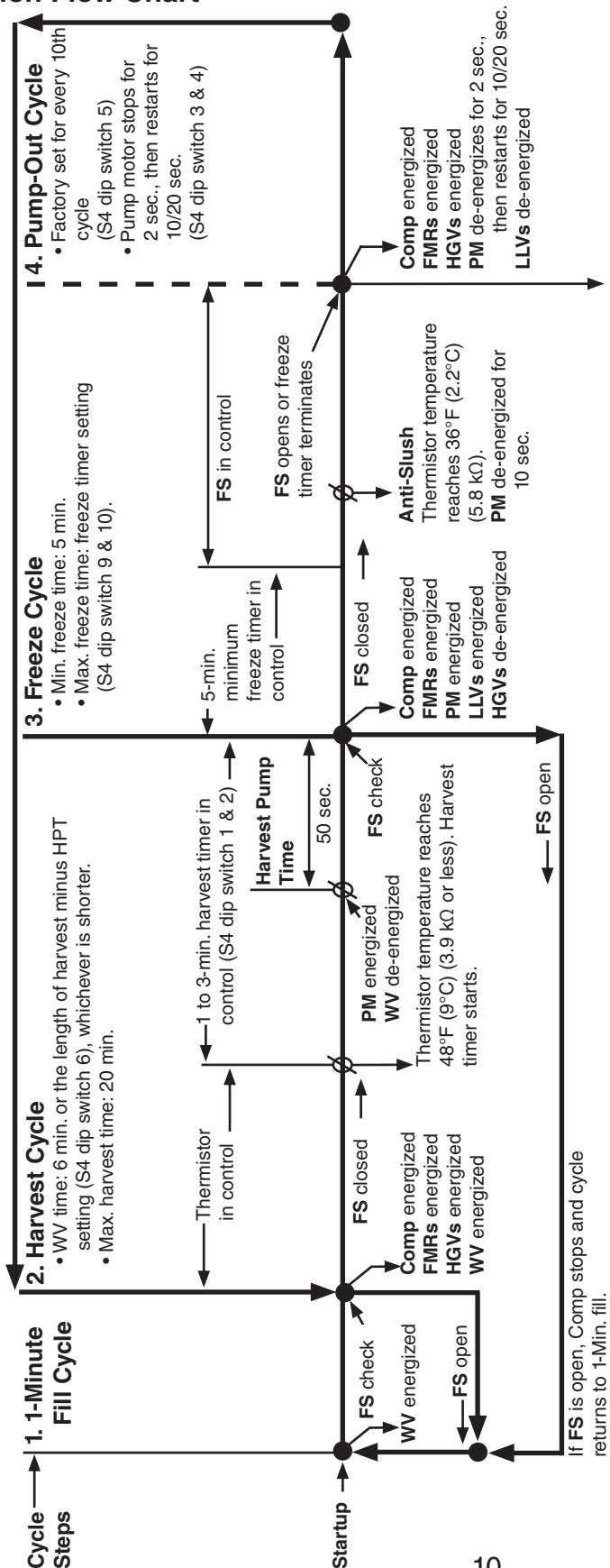

**CB - 2A7664-02:**  
When freeze time differential exceeded, freeze-time correction cycle starts.  
See "II.A.3. Freeze-Time Correction Chart."

#### Components Energized when the Control Switch is in the "SERVICE" Position

When in the "SERVICE" position, the control switch supplies power to the service switch and the icemaker is in service mode. The service switch has three positions: "DRAIN," "CIRCULATE," and "WASH." See the information below for details of each function.

DRAIN	Power is supplied to the pump and drain valve. This drains the water tank.
CIRCULATE	Power is supplied to the pump only. This operation can be used to circulate cleaner and sanitizer over the outside surface of the evaporator for extended periods of time.
WASH	Power is supplied to the pump and cleaning valve. This operation is used to circulate cleaner and sanitizer over both the inside and outside surfaces of the evaporator.

#### Legend:

- BC—bin control
- CB—control board
- Comp—compressor
- DV—drain valve
- FMRs—fan motors-remote
- FS—float switch
- HGVs—hot gas valves (KMS and SRK)
- HPT—harvest pump time
- LLVs—liquid line valves (KMS and SRK)
- PM—pump motor
- WV—inlet water valve

## 2. Shutdown Flow Chart

### Shutdown Flow Chart

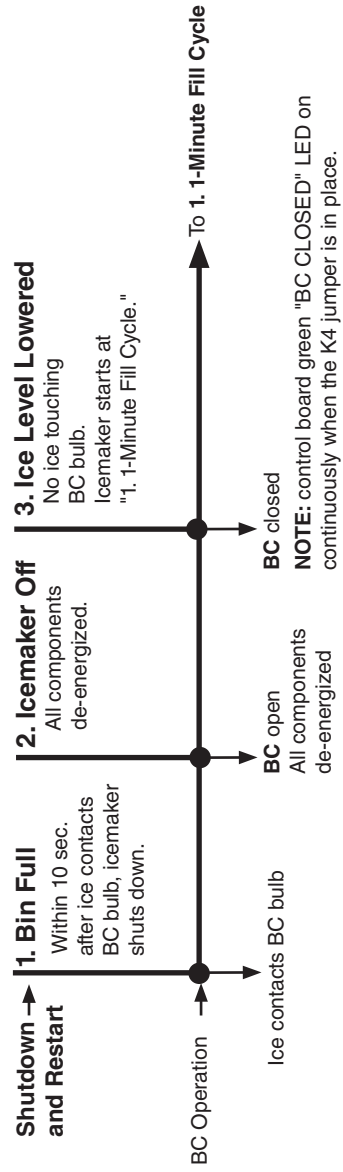

Control board retains freeze-time correction (CB: 2A7664-02 Only) count data between bin control restarts.

### 3. Freeze-Time Correction Flow Chart (CB: 2A7664-02)

## Freeze-Time Correction Flow Chart (CB: 2A7664-02)

**Freeze Time Differential Exceeded. Minimum and Maximum Freeze times have exceeded differential parameters.**

Freeze-Time Correction function is enabled when S4 Dip Switch 7 is in the "ON" position. CB monitors freeze time. After 3 freeze cycles, CB compares the minimum and maximum differential of the 3 freeze cycle times. Every freeze cycle time after the third freeze cycle time is added to the minimum/maximum calculation.  
 Example: After 8 cycles, if the differential between the shortest cycle (minimum) and the longest cycle (maximum) is equal to or greater than 427 sec. a freeze-time correction cycle is initiated:

Number of Freeze Cycles	Differential Value in Sec.
3	254
4	309
5	349
6	380
7	406
8	427
9	446
10	462

Note: When 1st freeze-time correction cycle is initiated, CB "POWER OK" LED starts blinking. On 2nd freeze-time correction cycle, if CB "POWER OK" LED has been reset, CB "POWER OK" LED starts blinking. If CB "POWER OK" had not been reset after 1st freeze-time correction cycle CB "POWER OK" LED continues to blink.  
 After 3rd freeze-time correction cycle in 36 hours, CB yellow "EXT HARVEST" LED starts blinking.  
 Appliance continues to operate and LEDs continue to blink until ALARM RESET button is pressed with power on.

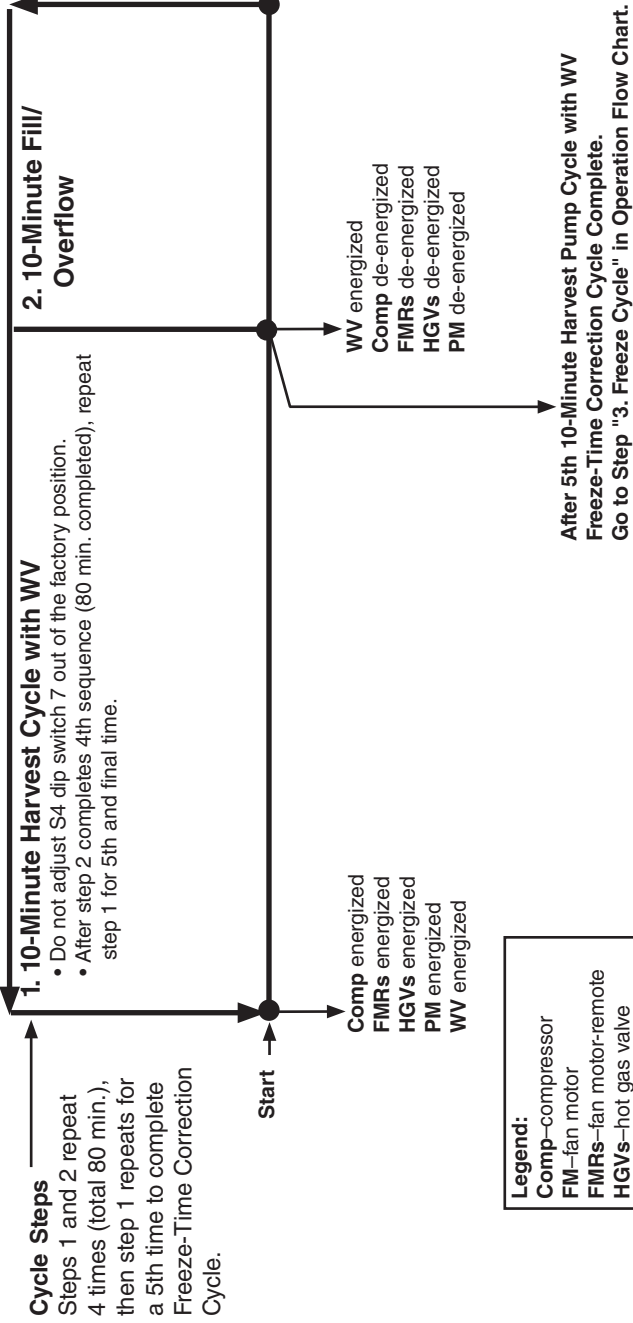

**Legend:**  
 Comp—compressor  
 FM—fan motor  
 FMRs—fan motor-remote  
 HGVs—hot gas valve  
 PM—pump motor  
 WV—inlet water valve

**Appliance Cycle Reset and Alarm Reset:**  
**Cycle Reset:** Power Supply or Control Switch Turned Off and On again: Appliance turns off, then restarts at 1 Fill Cycle.  
**Alarm Reset:** CB "ALARM RESET" pressed during or after a freeze-time correction cycle with power supply on:  
 Appliance continues cycle with no interruption or reset.  
 CB red "POWER OK" LED blinking:  
 CB red "POWER OK" LED resets to solid.  
 CB yellow "EXT HARVEST" LED blinking:  
 CB yellow "EXT HARVEST" LED turns off.

## B. Service Diagnosis

### WARNING

- The appliance should be diagnosed and repaired only by qualified service personnel to reduce the risk of death, electric shock, serious injury, or fire.
- Risk of electric shock. Use extreme caution and exercise safe electrical practices.
- Risk of electric shock. Control switch (KMS) in "OFF" position does not de-energize all loads.
- Moving parts (e.g., fan blade) can crush and cut. Keep hands clear.
- **CHOKING HAZARD:** Ensure all components, fasteners, and thumbscrews are securely in place after the appliance is serviced. Make sure that none have fallen into the dispenser unit/ice storage bin.
- Make sure all food zones in the icemaker and dispenser unit/ice storage bin are clean after service.

### 1. Diagnostic Procedure

The diagnostic procedure is a sequence check that allows you to diagnose the electrical system and components. Before proceeding, check for correct installation, proper voltage per nameplate, and adequate water supply.

Note: • When checking high voltage (115VAC), always choose a neutral (W) to establish a good neutral connection.

- On 3-phase models, the neutral (W) is provided through MT. To confirm a good neutral (W), check for 60VAC from neutral (W) to ground (GND). If 60VAC is present, neutral (W) is good. If 60VAC is not present, check 208-230VAC main power supply to MT. If 208-230VAC is present, check MT continuity.
- When checking voltage from the CB K1 connector (10 pin connector), pull CB K1 connector out slightly to allow room for multimeter test leads contact.

1) Turn off the power supply, then access the control box. Clear any ice from BC.

2) Check that the 115VAC 10A fuses in the KMS and SRK are good.

Confirm that the location meets installation requirements:

#### **KMS-1122MLJ:**

- The appliance is not intended for outdoor use. Normal operating ambient temperature should be within 45°F to 100°F (7°C to 38°C).
- Allow 15" (38 cm) clearance on left side for removal of spray tube and cube guide. There is no minimum clearance required for proper operation.
- The appliance should not be located in a corrosive environment.

#### **SRK-12J/3:**

- A dry and well ventilated area with 24" (61 cm) clearance in both front and rear for proper air circulation and ease of maintenance and/or service should they be required.

3) **Power On:** Turn on the power supply, then move the control switch to the "ICE" position. A 5-sec. delay occurs. CB red "POWER OK" LED and CB green "BC CLOSED" LED turn on. If CB yellow "BC OPEN" LED is on (indicating a full bin), check CB K4 red jumper. Move ice away from BC bulb.

Note: • CB red "POWER OK" LED remains on unless the 10.5VAC power supply is interrupted (K2 connector).

• Check CB using the steps in "II.D. Control Board Check."

a) **Power On Diagnosis:** If CB red "POWER OK" LED is off, confirm 10A fuse on both the KMS and the SRK are good. Confirm wire harness is connected and not damaged. Next, check SRK switches. Check for 115VAC at both HPS wires (BR) to neutral (W). If 115VAC is present on one and not the other, HPS is open. If HPS is open, see "b) **HPS Diagnosis**" below. If HPS is closed, check for 115VAC at both DLT wires (BR) to neutral (W). If 115VAC is present on one and not the other, DLT is open. If DLT is open, see "c) **DLT Diagnosis**" below. If DLT is closed, go to KMS and check for 115VAC at BC wires (BR) to neutral (W). If 115VAC is present on one and not the other, BC is open. See "II.E. Bin Control Check." If BC is closed, check for 115VAC at control switch #2 (BR) to neutral (W) then at control switch #3 (BK) to neutral (W). If 115VAC is present on #2 (BR) and not on #3 (BK), replace control switch. If 115VAC is present on control switch #3 (BK), check for 10.5VAC at CB K2 #1 red wire to CB K2 #2 red wire. If 10.5VAC is not present, check CT wire connections and CT continuity. If open, replace CT.

b) **HPS Diagnosis:** Check that all shutoff valves (4 total) are open and the condenser coil is not clogged or restricted. Let refrigeration circuit pressures equalize. If HPS does not reset and pressures are equalized, replace HPS. If pressures are not equalized, reclaim refrigerant and diagnose refrigeration circuit restriction. Check that there are no restrictions in the refrigeration circuit.  
Harvest Cycle: HGVs, strainer, or check valve.  
Freeze Cycle: FMRs, TXV, HM, LLVs, strainer, check valve, drier, and damaged line set or fitting.

c) **DLT Diagnosis:** Check that the condenser coil is not clogged or restricted. Let discharge line thermostat cool, if DLT does not close, replace DLT. Once closed, restart appliance, once Comp starts, check voltage and amp draw.  
See "5a),a) **Comp Diagnosis**" below.

- 4) **1-Min. Fill Cycle – LED 4 is on.** WV and X11 relay energize. After 1 min., CB checks for a closed FS. If FS is closed, the harvest cycle begins. If harvest cycle begins (Comp, HGVs, and FMRs energized), continue to step 5a. If FS is open, WV remains energized until FS closes (low water safety protection during initial start up and at the end of each harvest). **Diagnosis:** Check that water enters the water tank. If not, check that the water supply line shut-off valve is open and screens or external filters are clear. Check for 115VAC at CB K1 #6 (O) to neutral (W). If 115VAC is not present, replace CB. If 115VAC is present, and WV does not energize, check for 115VAC at WV. If 115VAC is present, check WV coil continuity. If open, replace WV. If the water tank fills, but the appliance fails to start harvest (Comp energized), check for open FS. See "II.F. Float Switch Check and Cleaning." If FS is closed and CB fails to start the harvest cycle after 1 min., replace CB.
- 5a) **Initial Harvest Cycle – LEDs 1, 4, and 2 are on.** WV and X11 relay continue. Comp, FMRs, HGVs, and X10 relay energize. CB monitors the warming of the evaporator via the thermistor located on the suction line. When the thermistor reaches 48°F (9°C), CB reads 3.9 kΩ from the thermistor and turns harvest termination over to the harvest timer (S4 dip switch 1 & 2 and S5 dip switch 4). WV and X11 relay are energized during harvest for a maximum of 6 min. or the length of harvest minus HPT setting (S4 dip switch 6), whichever is shorter. See step 5b below.
- a) **Comp Diagnosis:** Check that evaporator is warming. If not, confirm that Comp energizes. If not, check for 115VAC at CB K1 #1 (V) to neutral (W). If 115VAC is not present, check for 115VAC at CB K1 #10 (BR) to neutral (W). If 115VAC is present at #10 (BR) and not at #1 (V), replace CB. If 115VAC is present, check for 115VAC at MC solenoid (SRK). If 115VAC not present, check wire harness connections. If 115VAC is present, confirm contacts are closed. If not, replace MC. If MC contacts are closed, check Comp external overload, Comp start and run capacitors, Comp start relay (single phase), and Comp motor winding.
- b) **HGVs Diagnosis:** If Comp is energized and evaporator is not warming, check that HGVs energizes and open. Check for 115VAC at CB K1 #2 (P) to neutral (W). If 115VAC is not present, replace CB. If 115VAC is present, check for 115VAC at HGVs coil (KMS and SRK) and check HGVs coils continuity. Replace as needed.
- c) **LLVs Diagnosis:** Confirm that both LLVs are de-energized (KMS and SRK) and closed (not bypassing). If energized, replace CB. If de-energized and bypassing, replace LLVs (KMS and SRK).

5b) **Harvest Pump Timer – LEDs 1, 3, and 2 are on.** When the thermistor reaches 48°F (9°C), CB reads 3.9 kΩ from the thermistor and turns harvest termination over to the harvest timer (S4 dip switch 1 & 2 and S5 dip switch 4). When WV de-energizes, LED 4 turns off, X11 relay de-energizes and LED 3 turns on. PM energizes. Comp, FMRs, HGVs, and X10 relay continue.

**Diagnosis:** Place a thermometer on the suction line next to the thermistor. Has it warmed to 48°F (9°C) or warmer? Confirm thermistor status. See "II.G. Thermistor Check." If the thermistor reading is in proper range, dip switch 7 is on, and PM does not energize before harvest terminates, replace CB. If WV continues, check for 115VAC at CB K1 #6 (O). If 115VAC is present, and LED 4 is off, replace CB. If 115VAC is not present, and WV continues, check WV diaphragm for leaking by. Clean or replace. If LED 3 is on and PM is not energized, check for 115VAC at CB K1 #5 (DBU). If 115VAC is not present, replace CB. If 115VAC is present and PM is not energized, check for 115VAC at X10 relay terminal #8 (Y) to neutral (W). If 115VAC is not present, check for 115VAC at X10 relay terminal #4 (P) to neutral (W) and X10 relay terminal #6 (Y) to neutral (W). If 115VAC is present on terminal #4 (P) and not on terminal #6 (Y), replace X10 relay. If 115VAC is present on X10 relay terminal #8 (Y) and PM is not energized, check for 115VAC at X10 relay terminal #3 (R) to neutral (W) and terminal #5 (DBU) to neutral (W). If 115VAC is present on terminal #5 (DBU) and not on terminal #3 (R), replace X10 relay. If 115VAC is present on X10 relay terminal #3 (R), check control switch contact continuity between terminals #6 (R) and #5 (W/R). If contacts are open, replace control switch. If contacts are closed and 115VAC is present between control switch terminal #5 (W/R) and neutral (W), check PM capacitor and motor winding continuity.

5c) **Initial Harvest Cycle Termination Diagnosis:** When the thermistor reaches 48°F (9°C), CB reads 3.9 kΩ from the thermistor and turns harvest termination over to the harvest timer (S4 dip switch 1 & 2 and S5 dip switch 4). Check discharge line temperature. For a thermistor check, see "II.G. Thermistor Check." If 1-min. fill cycle starts after harvest timer terminates, check that FS is clean and operating properly, see "II.F. Float Switch Check and Cleaning." If FS is closed, CB proceeds to the next cycle. If not, replace CB.

Note: The minimum total time allowed by CB for a complete harvest cycle is based on S5 dip switch 4. Maximum harvest time allowed is 20 min.

**NOTICE! S4 dip switch 7 must remain on. Otherwise, PM will not energize during the last seconds of harvest.**

6) **Freeze Cycle – LED 1 is on.** Comp, FMRs, and PM continue. LLVs energize. HGVs and X10 relay de-energize. Appliance is held in freeze by a 5-min. short cycle protection timer. After 5-min. short cycle protection timer terminates and FS opens, freeze cycle terminates.  
Note: PM power supply switches from CB K1 #5 (DBU) in harvest to K1 #4 (R) in freeze.

**Anti-Slush:** When anti-slush is enabled (S5 dip switch 5 "ON"), PM de-energizes when thermistor reaches 36°F (2.2°C) (5.8kΩ) for 10 sec. then, energizes for the remainder of the freeze cycle.



- a) **Freeze Cycle Diagnosis:** Confirm Comp, FMRs, and PM continue. Confirm that LLVs energize. Next, confirm HGVs and X10 relay de-energize. During the first 5 min. of freeze, confirm evaporator is cooling. If not, confirm WV de-energized (not leaking by), HGVs de-energized (not bypassing), LLVs energizes, TXV and HM operate correctly, Comp is efficient, and refrigerant charge is correct. See "VIII.A. Specification and Performance Data Sheets."
- b) **Comp and FMRs Diagnosis:** If Comp and FMRs de-energize once freeze begins, check that appliance has not shut off on HPS or DLT ("POWER OK" LED off). If so, check "3)b) HPS Diagnosis" or "3)c) DLT Diagnosis" above. If CB "POWER OK" LED is on (KMS), check for 115VAC at CB K1 #9 (V) to neutral (W). If 115VAC is not present and LED 1 is on, replace CB. If 115VAC is present, check for 115VAC at MC coil (SRK). If 115VAC is not present, check wire harness connections. Next, check for 115VAC at MC coil. If 115VAC is present, check MC coil and contacts continuity. Replace as needed. If MC is okay, check Comp start relay and start and run capacitors (single phase). Next, check Comp motor winding continuity. If Comp is energized but evaporator is not cooling, check for an inefficient Comp. See "VIII.A. Specification and Performance Data Sheets."
- FMRs Diagnosis:** If Comp is energized but FMRs are not, check for 115VAC at MC terminal "NO" black (BK) wire to neutral (W). If 115VAC is not present, and MC is energized replace MC. If 115VAC is present, check FMRs capacitors, motor windings, and fan blades for binding.
- c) **WV and HGVs Diagnosis:** If WV is energized, check for 115VAC at CB K1 #6 (O) to neutral (W). If 115VAC is present after PM energizes in harvest cycle, replace CB. If 115VAC is not present, replace WV (bypassing). If HGVs (KMS and SRK) did not de-energize at the end of harvest, check for 115VAC at CB K1 #2 (P) to neutral (W). If 115VAC is present 50 sec. after PM energizes, replace CB. If 115VAC is not present, replace HGV(s) (bypassing).
- d) **PM Diagnosis:** Confirm water is flowing over evaporator from PM and not WV. If PM de-energizes once freeze begins (except for anti-slush), check for 115VAC at CB K1 #4 (R) to neutral (W). If 115VAC is not present, replace CB. If 115VAC is present and PM is de-energized, check for 115VAC at control switch #5 (W/R) to neutral (W). If 115VAC is present at CB K1 #6 (R) and not at control switch #5 (W/R), check control switch continuity between #5 (W/R) and #6 (R). Replace as needed. If 115VAC is present at control switch #5 (W/R) to neutral (W), check PM capacitor and motor winding continuity.
- e) **LLVs Diagnosis:** If LLVs does not energize, check for 115VAC at CB K1 #3 (BK) to neutral (W). If 115VAC is not present, replace CB. If 115VAC is present, check coil voltage and continuity.
- f) **Refrigerant Pressures, HM, and TXV Diagnosis:** If evaporator is still not cooling, check refrigerant pressures. See "VIII.A. Specification and Performance Data Sheets." Next, check HM operation. If refrigeration pressures are above HM setpoint and HM is bypassing, replace HM. Check TXV for proper operation. Remove TXV bulb and hold it in your hand, refrigerant low-side pressure should rise, place TXV bulb in ice water, refrigerant low-side pressure should drop. A 10 to 15 pound pressure swing between warm and cold conditions indicate a good TXV. If a 10 to 15 pound swing is not present, replace TXV.

g) **Freeze Termination Diagnosis:** After 5 min. in freeze, disconnect CB K5 FS connector. 15 sec. later appliance should switch out of the freeze cycle (15 second delay after FS opens before terminating the freeze cycle). If appliance remains in freeze longer than 15 sec. after FS removed, replace CB. If appliance switches with FS removed but would previously not switch out of freeze with FS connected (long freeze - 3 beep alarm), see "II.F. Float Switch Check and Cleaning."

Note: Normal freeze cycle will last 20 to 40 min. depending on model and conditions. Cycle times and pressures should follow performance data provided in this manual. See "VIII.A. Specification and Performance Data Sheets."

h) **Short Freeze Cycle Diagnosis:** Confirm water tank fills and overflows during 1 min. fill and harvest cycles. If not, check water supply filters, shut-off valve, WV screen. If water tank empties before 5 min. timer terminates and freeze cycle is short, check that DV is not leaking by or energized (water flowing through DV). If DV is leaking by, remove and clean DV, replace as needed. If water tank is full, see "II.F. Float Switch Check and Cleaning." for erratic operating FS.

7) **Pump-Out Cycle – LEDs 1, 3, and 2 are on (10/20 second pump-out).** Timing of the first pump-out is determined by S4 dip switch 5. See the table below.

Control Board Settings		
S4 Dip Switch Setting	Pump-Out Frequency	Control Board
No. 5		
OFF	Every 10 cycles	After 11th freeze cycle
ON	Every cycle	After 2nd freeze cycle

Comp and FMRs continue, HGVs energize.

Note: If S4 dip switch 3 & 4 are set to 3 off and 4 on, LED 4 turns on and WV and X11 relay energize, energizing X10 relay. **NOTICE! S4 dip switch 3 & 4 must not be set to 3 off and 4 on. Otherwise, LED 4 turns on energizing WV and X11 relay. X11 relay energizes X10 relay. Once X10 relay energizes, X12 relay cannot energize. Preventing DV from energizes.**

LLVs de-energize. PM stops for 2 sec., then restarts for 10/20 sec. depending on pump-out timer (S4 dip switch 3 & 4) setting. When the pump-out timer terminates, pump-out is complete. The pump-out frequency control (S4 dip switch 5) is factory set, and generally no adjustment is required. However, the pump-out frequency control can be set to have a pump-out occur every 10 cycles or every cycle. For details, see "III.C.4. Pump-Out Frequency Control (S4 dip switch 5)."

a) **Pump-Out Diagnosis:** In the freeze cycle before pump-out (see table above), after 5 min. of freeze disconnect CB black K5 connector (FS connector). Check that CB LEDs 1, 3, and 2 are on, PM stops, then restarts, DV energizes, and water is flowing down the drain through DV.

- b) **CB Diagnosis:** Confirm LLVs de-energize. If LLVs are energized with LEDs 1, 3, and 2 on, replace CB. If PM does not stop and restart and DV does not energize, check that CB LEDs 1, 3, and 2 are on. If not, replace CB. If LEDs 1, 3, and 2 are on and X12 relay is not energized, check for 115VAC at CB K1 #5 (DBU) to neutral (W). If 115VAC is not present, replace CB. If 115VAC is present at CB K1 #5 (DBU) and X12 relay is not energized, continue to "c) **X12 Relay Diagnosis:**" below. If X12 relay is energized and DV are not energized, check for 115VAC at CB K1 #2 (P) to neutral (W). If LED 2 is on and 115VAC is not present at CB K1 #2 (P), replace CB.
- c) **X12 Relay Diagnosis:** If 115VAC is present at CB K1 #5 (DBU) and CB K1 #2 (P) and X12 relay and DV is not energized, check for 115VAC at X12 relay #8 (DBU) to neutral (W). If 115VAC is not present, check wiring connections from CB K1 #5 (DBU) to X10 relay #5 (DBU), then at X10 relay #1 (DBU). If 115VAC is present at X10 relay #5 (DBU) and not at X10 relay #1 (DBU), confirm X10 relay is de-energized, if X10 relay is de-energized, replace X10 relay (sticking contacts). If 115VAC is present at X12 relay #8 (DBU) to neutral (W), and X12 is de-energized, check relay coil continuity. Replace as needed.
- d) **PM Diagnosis:** Check for 115VAC at X12 relay #6 (P) to neutral (W). If 115VAC is not present, see "b) **CB Diagnosis**" above. Next, check for 115VAC at X12 relay #4 (W/R) to neutral (W). If 115VAC is not present, confirm X12 relay is energized. If X12 relay is de-energized, see "c) **X12 Relay Diagnosis:**" above. If X12 relay is energized and 115VAC is present at X12 relay #6 (P) and not at X12 relay #4 (W/R), replace X12 relay. If 115VAC is present at X12 relay #4 (W/R) and PM is de-energized, check PM capacitor, motor winding, wiring connections, and impeller for binding.
- e) **DV Diagnosis:** Check for 115VAC at X12 relay #5 (P) to neutral (W) and at X12 relay #3 (GY) to neutral (W). If 115VAC is not present at X12 relay #5 (P), see "b) **CB Diagnosis:**" above. If 115VAC is present at X12 relay #5 (P) and not at X12 relay #3 (GY), confirm X12 relay is energized. If X12 relay is de-energized, see "c) **X12 Relay Diagnosis:**" above. If X12 relay is energized and 115VAC is present at X12 relay #5 (P) and not at X12 relay #3 (GY), replace X12 relay. If 115VAC is present at X12 #3 (GY) and DV is de-energized, check DV coil continuity, make sure the drain line is not clogged and that DV is clean and operating properly.
- 8) **Normal Harvest Cycle** – Same as the initial harvest cycle. Return to step 5a) above.  
Note: Appliance continues to cycle until BC is satisfied or power is switched off. The appliance always restarts at the 1-min. fill cycle.

## 2. Shutdown Diagnosis

When the appliance is running, hold ice in contact with the thermostatic bulb. BC switch opens within 10 sec., shutting down the appliance. BC is factory set, and generally no adjustment is required. However, adjustment may be needed in some conditions, particularly at higher altitude locations. Diagnosis: See "II.E. Bin Control Check." CB red K4 connector must have the jumper in place. When the jumper is in place, the green "BC CLOSED" LED remains on. If the jumper is not in place, yellow "BC OPEN" LED turns on and the icemaker turns off and remains off until the jumper is replaced in its original position. **NOTICE! CB red K4 connector jumper (4A4883G01) must be in place.**

## 3. Freeze-Time Correction Cycle Diagnosis

1) See "II.C. Freeze-Time Correction Cycle (90 min.) (CB: 2A7664-02)."

Legend: **BC**—bin control; **CB**—control board; **Comp**—compressor; **CT**—control transformer; **CV**—cleaning valve; **DV**—drain valve; **FMRs**—fan motor remote; **FS**—float switch; **HGVs**—hot gas valve; **HM**—headmaster (C.P.R.); **HPS**—high-pressure switch; **LLVs**—liquid line valve; **MC**—magnetic contactor; **MT**—main transformer; **PM**—pump motor; **TXV**—thermostatic expansion valve; **WV**—inlet water valve

### C. Freeze-Time Correction Cycle (90 min.) (CB: 2A7664-02)

Freeze-Time Correction function is enabled when S4 Dip Switch 7 is in the "ON" position and initiates when the difference between the minimum and maximum recorded freeze times is equal to or greater than values shown in the table below. Freeze time is recorded and freeze cycles are counted starting at the 2nd freeze cycle after startup from a power off condition. After 3 recorded freeze cycles, CB starts comparing the minimum and maximum differential of recorded freeze cycles times. Up to 10 freeze cycles are recorded and maintained in memory. At the 11th recorded freeze cycle, the first recorded freeze cycle time is dropped to maintain the maximum number of 10 recorded freeze cycles. Freeze time recordings and freeze cycle counts restart after a BC off cycle and resume at the 2nd freeze cycle after BC restart.

Example: After 8 cycles (excluding first cycle), if the differential between the shortest cycle (minimum) and the longest cycle (maximum) is equal to or greater than 427 sec. a freeze-time correction cycle is initiated:

Number of Freeze Cycles	Differential Value in Sec.
3	254
4	309
5	349
6	380
7	406
8	427
9	446
10	462

- 1) Initiation and CB Operation:** When the differential between minimum and maximum recorded freeze times exceeds the values in the table above, freeze-time correction cycle starts. CB red "POWER OK" LED blinks. When freeze-time correction cycle occurs 3 or more times within a 36 hour period, CB yellow "EXT HARVEST" LED blinks with CB red "POWER OK" LED. Appliance starts in freeze cycle after a freeze-time correction cycle. To reset CB LEDs, press ALARM RESET button on CB with power on. CB resets LEDs and appliance continues cycle without interruption.

## 2) Freeze-Time Correction Sequence:

**First occurrence** within 36 hr., minimum and maximum freeze times have exceeded differential parameters. CB "POWER OK" LED starts blinking. Freeze-Time Correction Cycle starts.

**Second occurrence** within 36 hr., minimum and maximum freeze times have exceeded differential parameters. If not reset, CB "POWER OK" LED continues blinking. If reset from first occurrence, CB "POWER OK" LED starts blinking. Freeze-Time Correction Cycle starts.

**Third occurrence** within 36 hr. minimum and maximum freeze times have exceeded differential parameters. CB yellow "EXT HARVEST" LED starts blinking. Also, If not reset, CB "POWER OK" LED continues blinking. If reset, CB "POWER OK" LED starts blinking. Freeze-Time Correction Cycle starts.

Total freeze-time correction cycle last for 90 min. At the end of 80 min., the final step initiates and final Harvest Pump Time (Harvest Assist) with WV (10-min.) starts. Once the final Harvest Pump Time (Harvest Assist) with WV (10-min.) terminates (90 min. complete), normal freeze cycle begins.

2a) **10-Min. Harvest Pump Time (Harvest Assist) with WV:** CB "POWER OK" LED blinking. CB LEDs 1, 4, 3, and 2 are on and Comp, FMRs, HGV, PM, and WV energize. 10-min. timer starts. Once 10-min. timer terminates, CB LEDs 1, 3, and 2 turn off and Comp, FMRs, HGV, and PM de-energize. WV continues.

2b) **10-Min. Fill:** CB LED 4 on and WV energized. 10-min. timer starts.

2c) **Final 10-Min. Harvest Pump Time (Harvest Assist) with WV:** CB "POWER OK" LED blinking. Once 10-min. timer terminates, CB LEDs 1, 4, 3, and 2 are on and Comp, FMRs, HGV, and PM energizes. WV continues. 10-min. timer starts. Once 10-min. timer terminates, normal freeze cycle begins. CB LED 1 on and Comp, FMRs, and PM continue. HGV and WV de-energize.

Note: After 3rd Freeze-Time Correction Cycle in 36 hours, CB signals with blinking CB yellow "EXT HARVEST" LED. Appliance continues normal operation.

CB "POWER OK" LED and CB yellow "EXT HARVEST" LED continue blinking in normal operation sequence.

## 3) Appliance Cycle Reset and CB Alarm Reset:

**Cycle Reset:** Power supply or control switch turned off and on again: Appliance turns off, then restarts at 1. Fill Cycle.

**Alarm Reset:** CB "ALARM RESET" pressed during or after a freeze-time correction cycle with power supply on: Appliance continues cycle with no interruption or reset.

CB red "POWER OK" LED blinking: CB red "POWER OK" LED resets to solid.

CB yellow "EXT HARVEST" LED blinking: CB yellow "EXT HARVEST" LED turns off.

Legend: **BC**—bin control; **CB**—control board; **Comp**—compressor; **CT**—control transformer; **CV**—cleaning valve; **DV**—drain valve; **FM**—fan motor; **FMRs**—fan motor remote; **FS**—float switch; **HGV**—hot gas valve; **HM**—headmaster (C.P.R.); **HPS**—high-pressure switch; **LLVs**—liquid line valve; **MC**—magnetic contactor; **PM**—pump motor; **TXV**—thermostatic expansion valve; **WV**—inlet water valve

## D. Control Board Check

Before replacing CB that does not show a visible defect and that you suspect is bad, always conduct the following check procedure. This procedure will help you verify your diagnosis.

Alarm Reset: If CB is in alarm (beeping), press the "ALARM RESET" button on CB while CB is beeping. **WARNING! Risk of electric shock. Care should be taken not to touch live terminals.** Once reset, the icemaker starts at the 1-minute fill cycle. For audible alarm information, see "III.B. LED Lights and Audible Alarm Safeties."

- 1) Check the dip switch settings to assure that S4 dip switch 3, 4, 7, 8, 9, 10 and S5 dip switch 1 through 5 are in the factory default position. S4 dip switch 1, 2, and 5 are cleaning adjustments and the settings are flexible. For factory default settings, see "III.C.1. Default Dip Switch Settings."
- 2) Move the control switch to the "ICE" position. If the red "POWER OK" LED is on, control voltage is good, continue to step 3. If the "POWER OK" LED is off, check CT secondary circuit. CT output is 10.5VAC at 115VAC primary input. If the secondary circuit has proper voltage and the red LED is off, replace CB.

If the secondary circuit does not have proper voltage (10.5VAC), check CT primary circuit. Check for 115VAC at control switch terminal #2 (BR) and control switch terminal #3 (BK) to neutral (W). If 115VAC is present at control switch terminal #2 (BR) and not at control switch terminal #3 (BK), replace control switch. If 115VAC is present at control switch terminal #3 (BK), check CT coil continuity. Replace as needed. For additional checks, see "II.I.1. No Ice Production."

- 3) The "OUTPUT TEST" button provides a relay sequence test. Make sure the control switch is in the "ICE" position, then press the "OUTPUT TEST" button. For the correct lighting sequence, see the table below. Note that the order of the LEDs from the outer edge of the control board is 1, 4, 3, 2. Components (e.g., compressor) cycle during the test.

Control Board	Correct LED Lighting Sequence
"J"	1, 4, 3, 2

Following the test, the icemaker begins operation at the 1-minute fill cycle for both. If the LEDs do not light as described above, replace CB.

- 4) To verify voltage output from CB to the components, slide the CB K1 connector out far enough to allow multimeter lead contact. With the icemaker in the cycle to be tested, check output voltage from the corresponding pin on CB K1 connector to a neutral (W). If output voltage is not found and the appropriate LED is on, replace CB.
- 5) Check CB control connectors K3, K4, and K5 for correct VDC per table below.  
Note: Pin #1 is DC ground (GND) on each connector.

Legend: **CB**–control board; **CT**–control transformer

K3 Thermistor	
Pin #	VDC
#1 to #2	5VDC
#1 to #3	5VDC
#2 to #3	0VDC

K4 Jumper	
Pin #	VDC
#1 to #2	5VDC
#1 to #3	5VDC
#2 to #3	0VDC

K5 Float Switch	
Pin #	VDC
#1 to #2	1.2VDC
#1 to #3	2VDC
#2 to #3	1.2VDC

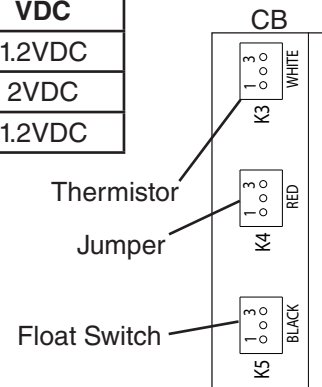



## E. Bin Control Check

To check BC, follow the steps below.

### **NOTICE**

When the ambient temperature is below 45°F (7°C), BC switch opens and shuts down the appliance even if the ice storage bin is empty. When BC is set in the prohibited range, the appliance operates continuously even if the ice storage bin is filled with ice. Setting in the prohibited range may result in severe damage to the appliance.

BC is factory set, and generally no adjustment is required. However, adjustment may be needed in some conditions, particularly at higher altitude locations.

Note:

- When BC switch is open, CB red "POWER OK" LED is off.
- CB yellow "BC OPEN" LED is on if CB red K4 connector does not have the jumper in place.

- 1) Turn off the power supply.
- 2) Remove the front panel, then move the control switch to the "OFF" position.
- 3) Clear any ice away from BC bulb.
- 4) Remove the control box cover, then disconnect BC wires from BC switch.
- 5) Hold your hand around BC bulb to warm it up.
- 6) Check for continuity across BC switch. If closed, continue to step 6. If open, adjust or replace BC.
- 7) With the multimeter test leads still in place, hold ice on BC bulb to lower the temperature. Within 10 sec., BC switch should open. If it remains closed, adjust or replace BC.

Legend: **BC**—bin control; **CB**—control board

## **F. Float Switch Check and Cleaning**

FS is used to confirm sufficient water in the water tank after the 1-min. fill cycle and after each harvest cycle. FS is also used to terminate the freeze cycle. No adjustment is required.

### **1. Float Switch Check**

To check FS, follow the steps below.

- 1) Turn off the power supply.
- 2) Remove the front panel.
- 3) Place the control switch in the "SERVICE" position. Then place the service switch in the "DRAIN" position.
- 4) Replace the front panel in its correct position, then turn on the power supply for 2 min.
- 5) Turn off the power supply.
- 6) Remove the front panel, then move the control switch to the "OFF" position.
- 7) Remove the control box cover, then disconnect FS connector from CB black K5 connector.
- 8) Check for continuity across FS leads. With the water tank empty, FS should be open. If open, continue to step 9. If closed, follow the steps in "II.F.2. Float Switch Cleaning." After cleaning FS, check it again. Replace if necessary.
- 9) Reconnect FS connector to CB black K5 connector, then replace the control box cover in its correct position.
- 10) Move the control switch to "ICE" position. Replace the front panel.
- 11) Turn on the power supply.
- 12) As water fills the water tank, FS contacts should close. After 1 min., the 1-min. fill cycle should end and the initial harvest cycle should begin. If harvest cycle doesn't start after 1 min. check continuity of FS with water tank full. If open, replace FS. If closed and harvest cycle has not started, replace CB.
- 13) Once the harvest cycle starts, turn off the power supply.
- 14) Remove the front panel, then move the control switch to the "OFF" position.
- 15) Remove the control box cover, then disconnect FS connector from CB black K5 connector.
- 16) Check for continuity across FS leads. With the water tank full, FS should be closed. If FS is closed and the appliance will not switch from the 1-min. fill cycle to the initial harvest cycle, replace CB.
- 17) If open, confirm that the water tank is full. If the water tank is not full, check the water supply, water filters, and inlet water valve. If the water tank is full, follow the steps in "II.F.2. Float Switch Cleaning." After cleaning FS, check it again. Replace if necessary.
- 18) Reconnect FS connector to CB black K5 connector, then replace the control box cover in its correct position.

- 19) Move the control switch to the "ICE" position.
- 20) Replace the front panel in its correct position.
- 21) Turn on the power supply to start the automatic icemaking process.

Legend: **CB**—control board; **FS**—float switch

## 2. Float Switch Cleaning

Depending on local water conditions, scale may build up on FS. Scale can cause FS to stick. In this case, FS should be cleaned.

- 1) Turn off the power supply.
- 2) Remove the front panel.
- 3) Place the control switch in the "SERVICE" position. Then place the service switch in the "DRAIN" position.
- 4) Replace the front panel in its correct position, then turn on the power supply for 2 min.
- 5) Turn off the power supply.
- 6) Remove the front, apron, top, left side panels, and side insulation, then move the control switch to the "OFF" position.
- 7) Remove FS assembly and FS stop. See Fig. 1.
- 8) Remove the retainer rod from the bottom of FS assembly, then remove the float. Be careful not to bend the retainer rod excessively when removing it.
- 9) Wipe down FS assembly's housing, shaft, float, and retainer rod with a mixture of 1 part Hoshizaki "Scale Away" and 25 parts warm water. Rinse the parts thoroughly with clean water.
- 10) Reassemble FS assembly and replace it and FS stop in their correct positions.
- 11) Replace the side insulation, left side, top, and apron panels in their correct positions.
- 12) Move the control switch to the "ICE" position.
- 13) Replace the front panel in its correct position.
- 14) Turn on the power supply to start the automatic icemaking process.

Legend: **CB**—control board; **FS**—float switch

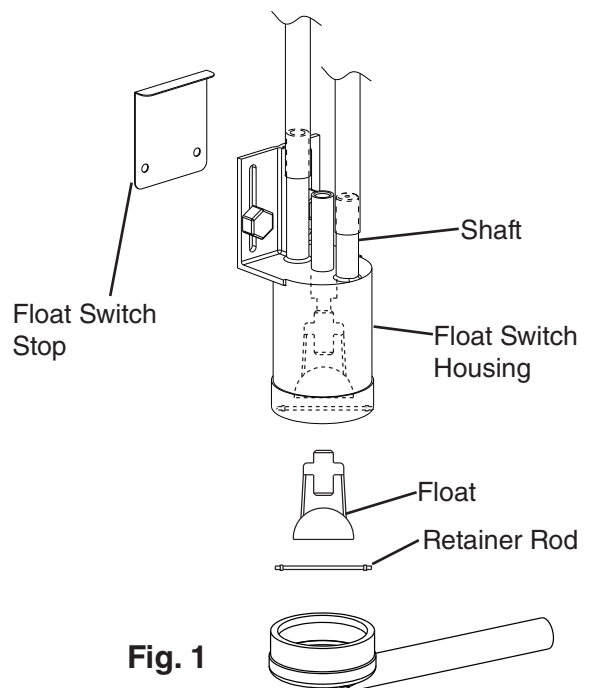

**Fig. 1**

## G. Thermistor Check

To check thermistor resistance, follow the steps below.

- 1) Turn off the power supply.
- 2) Remove the front panel, then move the control switch to the "OFF" position.
- 3) Remove the control box cover.
- 4) Remove the thermistor.
- 5) Immerse the thermistor sensor portion in a glass containing ice and water for 2 or 3 min.
- 6) Disconnect the thermistor connector from CB white K3 connector and check resistance between thermistor leads. Normal range is 4.7 to 6.2 k $\Omega$ . If outside the normal range, replace the thermistor. See "IV.B. Component Service Information." If within the normal range, continue to next step.
- 7) Replace the thermistor in its correct position. See "IV.B. Component Service Information."
- 8) Reconnect the thermistor connector to CB white K3 connector.
- 9) Replace the control box cover in its correct position.
- 10) Move the control switch to the "ICE" position.
- 11) Replace the front panel in its correct position.
- 12) Turn on the power supply.
- 13) Once the harvest cycle starts (Comp energizes), begin timing the harvest cycle.
- 14) The harvest timer and harvest cycle should terminate within 2 to 5 min. If the harvest cycle does not terminate within 2 to 5 min., replace CB.

Legend: **CB**—control board; **Comp**—compressor

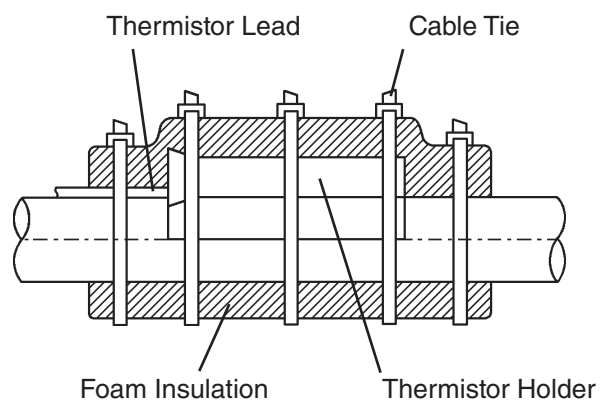

**Fig. 2**

## H. Switches

Two control switches are used to control operation. These switches are referred to as the "control switch" and the "service switch" and are located on the control box.

### 1. Control Switch

The control switch has three positions: "OFF" for power off, "ICE" for icemaking, and "SERVICE" to activate the service switch. **WARNING! Moving control switch to "OFF" position does not de-energize all components.**

### 2. Service Switch

When the control switch is in the "SERVICE" position, the control switch supplies power to the service switch and water pump. The machine is in service mode. The service switch has three positions: "DRAIN," "CIRCULATE," and "WASH." See the information below for details of each function.

Note:

1. When the service switch is activated, power is supplied to the water pump in all three positions.
2. When the control switch is in the "OFF" position or in the "ICE" position, the service switch has no power and can be left in any position.

#### a) **DRAIN**

This appliance utilizes a pump-out drain system. When the service switch is active and placed in the "DRAIN" position, power is supplied to the drain valve.

#### b) **CIRCULATE**

When the service switch is active and placed in the "CIRCULATE" position, power is supplied to the water pump only. This operation can be used to circulate cleaner for extended periods of time over the outside surface of the evaporator.

#### c) **WASH**

This appliance utilizes a solenoid operated wash (bypass) valve. When the service switch is active and placed in the "WASH" position, power is supplied to the water pump and wash valve. This operation is used to circulate cleaner and sanitizer over both the inside and outside of the evaporator.

## I. Diagnostic Tables

Before consulting the diagnostic tables, check for correct installation, proper voltage per nameplate, and adequate water pressure (10 to 113 PSIG). Check control board using the steps in "II.D. Control Board Check."

### 1. No Ice Production

No Ice Production - Possible Cause	
1. Power Supply	a) Off, blown fuse, or tripped breaker.
	b) Not within specifications.
2. Main Transformer (3 phase SRK) (208-230VAC/115VAC)	a) Voltage tap switch not set to proper voltage.
	b) No neutral. White wire (W) to ground 0VAC. (white wire (W) to ground 60VAC).
3. Water Supply	a) Water supply off or improper water pressure.
	b) External water filters clogged.
4. Fuse (SRK Control Box)	a) Blown.
5. High-Pressure Switch (SRK)	a) Dirty condenser.
	b) Condensing unit fan(s) not operating.
	c) Headmaster (C.P.R.) open.
	d) Refrigerant overcharged.
	e) Bad contacts.
	f) Refrigerant lines or components plugged.
6. Discharge Line Thermostat (SRK)	a) Ambient temperature too warm.
	b) Compressor or compressor components faulty.
	c) Defective.
	d) Hot gas valves open.
	e) Dirty condenser.
	f) Condensing unit fan(s) not operating.
7. Wire Harness (From SRK to KMS)	a) Disconnected or loose connection.
8. Fuse (KMS Control Box)	a) Blown.
	a) Tripped with bin filled with ice.
9. Bin Control See "II.E. Bin Control Check"	b) Ambient temperature too cool.
	c) Bulb out of position.
	d) Set too warm.
	e) Defective.
	f) K4 connector does not have jumper in place.
	10. Control Switch
b) Bad contacts.	
11. Control Transformer (115VAC/10.5VAC)	a) Coil winding open or shorted.
12. Control Board See "II.D. Control Board Check"	a) In alarm.
	b) Yellow "BC OPEN" LED on (jumper loose or missing).
	c) Defective.

<b>No Ice Production - Possible Cause</b>	
13. Inlet Water Valve	a) Screen or orifice clogged.
	b) Coil winding open.
	c) Water valve open in freeze cycle.
14. Float Switch See "II.F. Float Switch Check and Cleaning"	a) Float does not move freely.
	b) Defective.
15. Compressor	a) Magnetic contactor contacts bad or coil winding open.
	b) Start capacitor or run capacitor defective (1 phase SRK).
	c) Start relay contacts bad or coil winding open (1 phase SRK).
	d) Internal protector open.
	e) Compressor defective.
16. Hot Gas Valves (KMS & SRK)	a) Closed in harvest cycle.
	b) Open in freeze cycle.
17. Thermistor See "II.G. Thermistor Check"	a) Loose, disconnected, or defective.
18. Pump Motor	a) Motor winding open.
	b) Bearing worn out or locked rotor.
	c) Defective capacitor.
19. Thermostatic Expansion Valve	a) Bulb loose.
	b) Operating erratically.
20. Liquid Line Valves (KMS & SRK)	a) Closed in freeze cycle.
	b) Open in harvest cycle.
21. Fan Motors-Remote	a) Magnetic contactor contacts bad or coil winding open.
	b) Motor winding open.
	c) Bearing worn out or locked rotor.
	d) Defective capacitor.
22. Headmaster	a) Defective.
23. Water System	a) Water leaks causing short freeze time.

## 2. Freeze-Up

Defrost and clean the icemaker prior to diagnosing freeze-up. Fill out a freeze-up checklist. The freeze-up checklist can be found in the Hoshizaki Technician's Pocket Guide or contact your local distributor for a copy of the freeze-up checklist.

<b>Freeze-Up - Possible Cause</b>	
<b>Harvest Cycle</b>	
1. Evaporator	a) Scaled up. b) Damaged.
2. Cube Guides	a) Out of position. b) Damaged.
3. Spray Tubes and/or Spray Guides	a) Dirty. b) Out of position.
4. Water Supply	a) Low water pressure. b) External water filters clogged. c) Insufficient water line size. Minimum 3/8" nominal ID copper water tubing or equivalent.
5. Inlet Water Valve	a) Defective.
6. Float Switch See "II.F. Float Switch Check and Cleaning"	a) Float does not move freely. b) Defective.
7. Refrigerant Charge	a) Low.
8. Control Board See "III. Controls and Adjustments" and "II.D. Control Board Check"	a) Harvest timer (S4 dip switch 1 & 2) set too short. b) Harvest pump timer (S4 dip switch 7) not in factory default position. c) Defective.
9. Bin Control See "II.E. Bin Control Check"	a) Bulb out of position. b) Defective.
10. Thermistor See "II.G. Thermistor Check"	a) Loose, disconnected, or defective.
11. Thermostatic Expansion Valve	a) Defective.
12. Hot Gas Valves (KMS & SRK)	a) Closed or restricted.
13. Liquid Line Valves (KMS & SRK)	a) Open.
<b>Freeze Cycle</b>	
1. Evaporator	a) Scaled up. b) Damaged.
2. Spray Tubes, Spray Guides, or Splash Guard	a) Dirty. b) Out of position.
3. Refrigerant Charge	a) Low.
4. Control Board See "II.D. Control Board Check"	a) Freeze timer (S4 dip switch 9 & 10) set incorrectly. b) Defective.
5. Inlet Water Valve	a) Leaking by.
6. Float Switch See "II.F. Float Switch Check and Cleaning"	a) Float does not move freely. b) Defective.
7. Pump Motor	a) RPM too slow. b) Impeller damaged.



<b>Freeze-Up - Possible Cause</b>	
8. Thermostatic Expansion Valve	a) Bulb loose or defective.
9. Headmaster	a) Defective.
10. Liquid Line Valves (KMS & SRK)	a) Restricted.

### 3. Low Ice Production

<b>Low Ice Production - Possible Cause</b>	
<b>Long Harvest Cycle</b>	
1. Evaporator	a) Scaled up.
2. Spray Tubes, Spray Guides, and Splash Guard	a) Dirty.
	b) Out of position.
3. Refrigerant Charge	a) Low.
4. Water Supply	a) Low water pressure.
	b) External water filters clogged.
	c) Insufficient water line size. Minimum 3/8" nominal ID copper water tubing or equivalent.
	d) Too cold.
5. Control Board See "II.D. Control Board Check"	a) Thermistor connection loose (K3).
	b) Defective.
6. Thermistor See "II.G. Thermistor Check"	a) Loose, disconnected, or defective.
7. Hot Gas Valves (KMS & SRK)	a) Erratic or closed.
8. Inlet Water Valve	a) Screen or orifice clogged.
9. Compressor	a) Inefficient or off.
10. Liquid Line Valves (KMS & SRK)	a) Erratic or open.
11. Thermostatic Expansion Valve (TXV)	a) Defective.
12. Headmaster	a) Defective.
<b>Long Freeze Cycle</b>	
1. Evaporator	a) Scaled up, dirty.
2. Float Switch See "II.F. Float Switch Check and Cleaning"	a) Scaled up, dirty.
	b) Float sticking.
	c) Defective switch.
3. Inlet Water Valve	a) Leaking by.
4. Hot Gas Valves (KMS & SRK)	a) Erratic or open.
5. Condenser	a) Clogged.
6. Control Board See "II.D. Control Board Check"	a) Float switch connection loose (K5).
	b) Defective.
7. Refrigerant Charge	a) Low.
8. Thermostatic Expansion Valve (TXV)	a) Bulb loose.
	b) Defective.
9. Compressor	a) Inefficient or off.
10. Pump Motor	a) RPM too slow.
11. Liquid Line Valves (KMS & SRK)	a) Erratic or restricted.
12. Headmaster	a) Defective.

# J. Freeze-Up Check List

**Freeze-Up Check List**  
**Please Complete When Diagnosing a Freeze-Up, Refrigerant Leak, or Low Charge**  
 Technical Support Fax #: 770-487-3360  
 Make Copies And Use As Needed

**Model #** \_\_\_\_\_ **Serial #** \_\_\_\_\_ **Install Date** \_\_\_\_\_ **Fail Date** \_\_\_\_\_

List model and manufacture of bin or dispenser \_\_\_\_\_.

Date appliance was last cleaned: \_\_\_\_\_.

**Freeze-Up Defrost**

- YES NO  
  1) After defrosting, was the appliance leak checked?  
  2) Were any leaks found?  
 If so where? \_\_\_\_\_.  
  3) Was any refrigerant added to the unit?  
 If so, how much? \_\_\_\_\_.

**Set Up**

- 4) Is the appliance stacked?  
  5) Is water line independent?  
  6) Is water line correct size? If not \_\_\_\_\_":  
 3/8" Nominal ID Copper Water Tubing or Equivalent.  
  7) What is water pressure? \_\_\_\_\_.  
 Water Temperature \_\_\_\_\_.  
  8) Does appliance have any water filtration?  
 If yes please list the following:  
 Filter brand \_\_\_\_\_.  
 Model \_\_\_\_\_.  
 Filter pressure gauge reading during the fill cycle \_\_\_\_\_.  
 Date filter was last replaced? \_\_\_\_\_.  
 GPM or LPM flow rate of filter system? \_\_\_\_\_.  
  9) Ambient temperature at appliance? \_\_\_\_\_.  
 At remote condenser (if applicable)? \_\_\_\_\_.

**Appliance Status**

- 10) Is the appliance and/or float switch dirty?  
  11) List the S4 (1-10) and S5 (1-5) DIP switch settings.  
 S4: 1 \_\_\_ 2 \_\_\_ 3 \_\_\_ 4 \_\_\_ 5 \_\_\_ 6 \_\_\_ 7 \_\_\_ 8 \_\_\_ 9 \_\_\_ 10 \_\_\_  
 S5: 1 \_\_\_ 2 \_\_\_ 3 \_\_\_ 4 \_\_\_ 5 \_\_\_  
  12) Is DIP switch number 7 ON (harvest pump time (harvest assist) all models and freeze-time correction models with control board 2A7664-02?  
  13) Is the cube guide positioned correctly?  
  14) Are the evaporator separators positioned properly?  
  15) Is the thermistor properly mounted, tight, and insulated?  
  16) Is the TXV bulb properly mounted, tight, and insulated?

**Appliance Operation**

- YES NO **Fill**  
  17) Does the water tank fill and overflow? 60-90 sec. Note: Larger models may take up to 120 seconds to overflow when empty.  
  18) If NO in step 17, is water flow 5GPM for larger?  
  19) Does the appliance utilize re-fill (S5 dip switch 2 and 3)?

**Harvest**

- 20) Is the hot gas valve opening?  
  21) Is harvest pump time (harvest assist) utilized (S4 dip switch 7)?  
  22) Is hot gas valve opening in harvest?  
  23) Does water valve close completely when deenergized?  
  24) What was length of harvest? \_\_\_\_\_.

**Freeze**

- 25) Is pump motor energized in freeze cycle except during 10-sec. anti-slush. If activated (S5 dip switch 5 on)?  
  26) Water-cooled condenser outlet temperature 5-min. into freeze? \_\_\_\_\_ °F.  
  27) What was length of freeze? \_\_\_\_\_.  
  28) Is the cube size consistent from inlet to outlet of evaporator?  
  29) Is ice still dropping when next freeze cycle starts?  
  30) What is the ice drop weight? \_\_\_\_\_.  
  31) What is head pressure?  
 Freeze \_\_\_\_\_ Harvest \_\_\_\_\_.  
 (Freeze pressure should be taken 5 minutes into the cycle).  
  32) What is suction pressure?  
 Freeze \_\_\_\_\_ Harvest \_\_\_\_\_.  
 (Freeze pressure should be taken 5 minutes into the cycle).  
  33) When activating bin control, did appliance shutdown within 15 seconds in the first 5 minutes of freeze cycle?

**Freeze-Time Correction Operation**

- 34) Has Freeze-Time Correction been activated? ("POWER OK" LED blinking).  
  35) Has more than 1 Freeze-Time Correction been activated? (POWER OK" LED and "EXT HARVEST" LED blinking).

Note: Make copies of this form and use it when diagnosing a freeze up condition. Submit a completed copy of the checklist along with the freeze-up labor claim form.

---

### III. Controls and Adjustments

- A Hoshizaki exclusive control board is employed in the KMS-1122MLJ series.
- All models are pretested and factory adjusted.
- For a control board check procedure, see "II.D. Control Board Check."

#### ***NOTICE***

- Fragile, handle very carefully.
- The control board contains integrated circuits, which are susceptible to failure due to static discharge. It is especially important to touch the metal part of the appliance when handling or replacing the control board.
- Do not touch the electronic devices on the control board or the back of the control board.
- Do not change wiring and connections. Do not misconnect terminals.
- Do not short out power supply to test for voltage.
- Always replace the whole control board assembly if it goes bad.

# A. Control Board Layout

## "J" Control Board

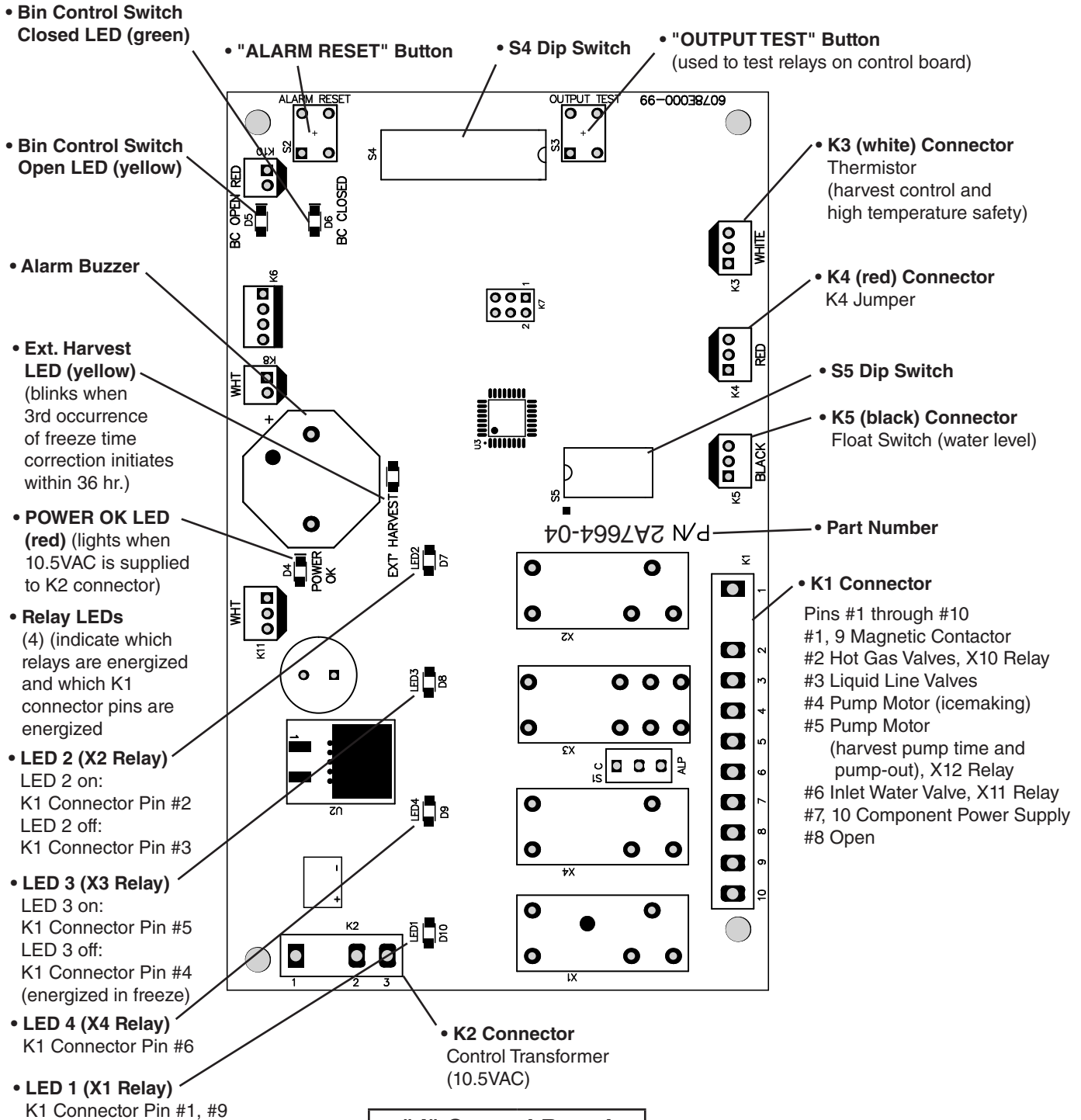

"J" Control Board	
Part Number	2A7664-04

## B. LED Lights and Audible Alarm Safeties

Beep occurs and red "POWER OK" LED turns on when control switch is moved to "ICE" position.

### Sequence

Green LEDs 1 through 4 turn on and sequence from initial startup as listed in the table below. Order of green LEDs from the outer edge of control board is 1, 4, 3, 2.

Sequence Step	LED	Energized Components	Time LEDs are On	
			Min.	Max.
1-Minute Fill Cycle	4	WV		
Harvest Cycle	1, 4, 2	Comp, FM*, FMR, HGV, WV	1 minute	20 minutes
Harvest Pump Time (harvest assist)	1, 3, 2	Comp, FM*, FMR, HGV, PM	0 seconds	50 seconds
Freeze Cycle	1	Comp, FM/FMR, PM, LLV	5 minutes	freeze timer setting
Anti-Slush Control	1, 3	Comp, FM/FMR, LLV	If S5 dip switch 5 on, PM off 10 sec. when thermistor at 36°F (2.2°C)	
Pump-Out Cycle	1, 4 <sup>†</sup> , 3, 2	Comp, FM*, FMR, HGV, PM, WV <sup>†</sup> , DV	10 seconds	20 seconds

\*FM energized if on K1 Connector Pin #9; <sup>†</sup>pump-out timer setting

### Alarms

Type	Alarm	Notes
1 Beep	High Evaporator Temp. (temperature > 127°F) (53°C)	Check for harvest problem (stuck HGV or relay), hot water entering unit, stuck HM, or shorted thermistor.
2 Beep	Harvest Backup Timer (harvest > 20 min. for two cycles in a row)	Check thermistor (open), HGV not opening, TXV or LLV leaking by, low charge, inefficient Comp, or WRV leaking by.
3 Beep	Freeze Timer (freeze > freeze timer setting for two cycles in a row)	Check FS stuck closed (up), WV leaking by, HGV leaking by, PM not pumping, TXV defective, LLV not opening, low charge, HM not bypassing, or inefficient Comp.
LED Blink	Freeze-Time Correction (CB-2A7664-02) (maximum freeze time differential exceeded)	Red POWER OK LED blinks. After 3 freeze-time correction cycles in 36 hours, yellow EXT HARVEST LED also blinks. Fill out freeze-up checklist. See "II.J. Freeze-Up Check List."
To reset above safeties, press "ALARM RESET" button with power supply on.		
6	Low Voltage (92Vac±5% or less)	Red LED turns off if voltage protection operates. Control voltage safeties automatically reset when voltage is corrected.
7	High Voltage (147Vac±5% or more)	

Legend: **CB**—control board; **Comp**—compressor; **FM**—fan motor; **FMR**—fan motor remote; **FS**—float switch; **HGV**—hot gas valve; **HM**—headmaster (C.P.R.); **LLV**—liquid line valve; **PM**—pump motor; **TXV**—thermostatic expansion valve; **WRV**—water regulating valve; **WV**—inlet water valve

## C. Settings and Adjustments

### NOTICE

Dip switches are factory set. Failure to maintain factory settings may adversely affect performance and warranty coverage. For more information, contact Hoshizaki Technical Support at 1-800-233-1940.

### 1. Default Dip Switch Settings

The dip switches are factory-adjusted to the following positions:

S4 Dip Switch										
Dip Switch No.	1	2	3	4	5	6	7	8	9	10
KMS-1122MLJ	OFF	OFF	OFF	OFF	ON	OFF	ON	OFF	OFF	OFF

S5 Dip Switch (Do Not Adjust)					
Dip Switch No.	1	2	3	4	5
KMS-1122MLJ	OFF	OFF	OFF	OFF	ON

#### S4 Dip Switch

#### "J" Control Boards

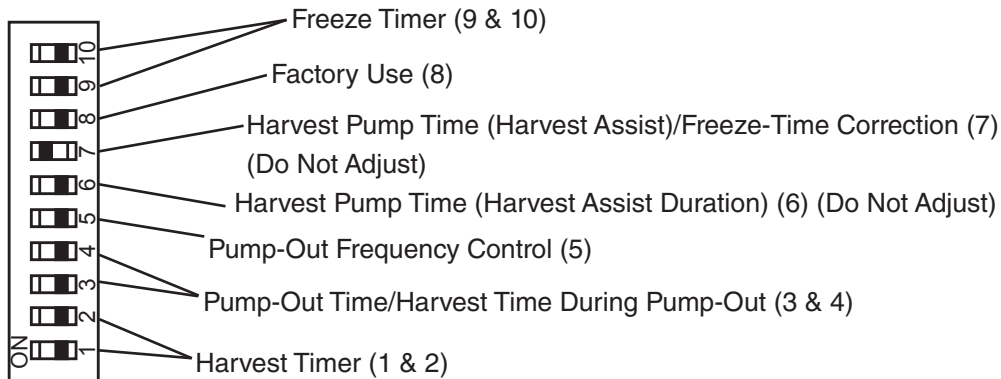

#### S5 Dip Switch

#### "J" Control Board Only

Do Not Adjust

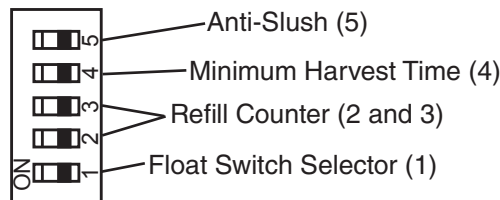

## 2. Harvest Timer (S4 dip switch 1 & 2)

The harvest timer starts counting when the thermistor reaches 48°F (9°C) at the evaporator outlet and the control board reads 3.9 kΩ from the thermistor. The harvest timer is factory set, and generally no adjustment is required. However, a setting longer than the factory setting may be advised in cases where the drain provided at harvest needs to be prolonged for extra cleaning. Before changing this setting, contact Hoshizaki Technical Support at 1-800-233-1940 for recommendations. Keep in mind that setting the harvest timer to a longer setting decreases 24-hour production.

Note that the pump-out timer (S4 dip switch 3 & 4) acts in place of the harvest timer during cycles with a pump out. For details, see "III.C.3. Pump-Out Timer (S4 dip switch 3 & 4)."

Note: On models with a pump-out every cycle, the harvest timer is only relevant during the initial harvest cycle since a pump out occurs every cycle thereafter.

S4 Dip Switch Setting		Time (sec.)
No. 1	No. 2	
OFF	OFF	60
ON	OFF	90
OFF	ON	120
ON	ON	180

## 3. Pump-Out Timer/Harvest Time During Pump-Out (S4 dip switch 3 & 4)

### **NOTICE**

- Do not adjust 3 off and 4 on. Drain valve does not energize in this setting.

When a pump-out is called for, the pump motor stops for 2 sec. After 2 sec. the drain valve and pump motor energize. Water is removed from the bottom of the water tank and sent down the drain. The pump-out drains the water tank for the time determined by the pump-out timer. The pump-out timer also acts in place of the harvest timer during cycles with a pump-out. The pump-out timer is factory set, and generally no adjustment is required. However, where water quality is bad and the icemaker needs a longer pump-out time, the pump-out timer can be adjusted. The pump-out timer control can be set to pump-out for 10 or 20 sec.

S4 Dip Switch Setting		Time (sec.)			Inlet Water Valve	
No. 3	No. 4	T1	T2		S5-4 OFF	S5-4 ON
			S5-4 OFF	S5-4 ON		
OFF	OFF	10	150	100	Closed	Closed
ON	OFF	10	180	130	Closed	Closed
OFF	ON	10	120	70	Open	Closed
ON	ON	20	180	180	Closed	Closed

T1: Time to drain the water tank

T2: Harvest timer at pump out

#### 4. Pump-Out Frequency Control (S4 dip switch 5)

The pump-out frequency control is factory set to drain the water tank every 10 cycles. Generally no adjustment is required. However, where water quality is bad and the icemaker needs a pump-out more often, the pump-out frequency can be adjusted. The pump-out frequency control can be set to have a pump-out occur every cycle, or every 10 cycles.

The first pump-out is dependent on S4 dip switch 5. See the table below.

S4 Dip Switch Setting	Pump-Out Frequency	1st Pump-Out
No. 5		
OFF	Every 10 cycles	After 11th freeze cycle
ON	Every cycle	After 2nd freeze cycle

#### 5. Harvest Pump Time (Harvest Assist Duration) (S4 dip switch 6)

### **NOTICE**

Factory set for proper operation. Do not adjust. Adjustment outside of the factory default setting may result in damage to the appliance.

Harvest pump time (harvest assist duration) is only active when S4 dip switch 7 is in the "ON" position. In the factory default position, the harvest pump time (harvest assist duration) starts with 50 sec. left to go in harvest cycle (S4 dip switch 6) and after the thermistor reaches 48°F (9°C) at the evaporator outlet and the control board reads 3.9 kΩ from the thermistor. The harvest pump time (harvest assist duration) is factory set, and no adjustment is required.

S4 Dip Switch Setting	Harvest Pump Time (Harvest Assist Duration)	
	S5-4 OFF	S5-4 ON
No. 6		
OFF	50 sec.	25 sec.
ON	25 sec.	15 sec.



## 6. Harvest Pump Time (Harvest Assist)/Freeze-Time Correction (S4 dip switch 7)

### **NOTICE**

Factory set for proper operation. Do not adjust. Adjustment outside of the factory default setting may result in damage to the appliance.

#### a) Harvest Pump Time (Harvest Assist)

Depending on S4 dip switch 7 setting, the pump motor either stays off or is energized during the last seconds of the harvest cycle. When the pump motor is energized (S4 dip switch 7 on), water circulates over the evaporator. The harvest water valve is open during harvest for a maximum of 6 minutes or the length of harvest minus the harvest pump time value(S4 dip switch 6), whichever is shorter.

When S4 dip switch 7 is in the on position and harvest begins, X11 and X10 relays energize. A latching circuit is created through the X11 and X10 relays. For further details, see "VIII.B. Wiring Diagrams." In the factory default position, 50 sec. before harvest termination, LED 4 turns off, inlet water valve and X11 relay de-energize. X10 relay remains energized through the latching circuit. Next, LED 3 turns on and control board K1 connector pin #5 (DBU wire) energizes, energizing the pump motor through contacts on the energized X10 relay (#5 and #3) for the last seconds of harvest. Harvest pump time adjusted by S4 dip switch 1 & 2 and S5 dip switch 4 settings. Contact Technical Support before adjusted these settings.

#### b) Freeze-Time Correction (CB: 2A7664-02)

When S4 dip switch 7 is in the on position, freeze-time correction enabled.  
See "II.C. Freeze-Time Correction Cycle (90 min.) (CB: 2A7664-02)."

<b>S4 Dip Switch Setting</b>	<b>Harvest Pump Time (Harvest Assist)</b>	<b>Freeze-Time Correction (CB: 2A7664-02)</b>
<b>No. 7</b>		
OFF		Disabled
ON		Enabled

## 7. Factory Use (S4 dip switch 8)

Factory set for proper operation. Do not adjust. This must be left in the factory default position.

## 8. Freeze Timer (S4 dip switch 9 & 10)

### **NOTICE**

Adjust to proper specification, or the icemaker may not operate correctly.

The freeze timer setting determines the maximum allowed freeze time to prevent possible freeze-up issues. Upon termination of the freeze timer, the control board initiates the harvest cycle or pump-out cycle. After 2 consecutive freeze timer terminations, the control board shuts down the icemaker. In this case, see "II.1.3. Low Ice Production" for possible solutions. The freeze timer is factory set and no adjustment is required. Before changing this setting, contact Hoshizaki Technical Support at 1-800-233-1940 for recommendations.

S4 Dip Switch Setting		Time (min.)
No. 9	No. 10	
OFF	OFF	60
OFF	ON	50
ON	OFF	70
ON	ON	75

## 9. Float Switch Control Selector for Refill (S5 dip switch 1)

### **NOTICE**

Do not adjust. This must be left in the factory default position or the icemaker will not operate correctly. This setting is ignored if refill counter (S5 dip switch 2 and 3) set to 0. The KMS-1122MLJ uses a single float switch with no refills.

Float switch control selector for refill is used in applications where refill is required in the freeze cycle.

- With S5 dip switch 1 in the "OFF" position, control board monitors the lower float switch for refill operation.
- With S5 dip switch 1 in the "ON" position, the control board monitors the upper float switch for refill operation. If single float, no upper float switch exists, therefore the control board reads an open upper float switch immediately when the freeze cycle starts and initiates a refill. Since there is no upper float switch to close and terminate the refill, the refill lasts for a maximum of 1-min. and occurs 1 time only. During the 1-min. refill, LED 4 is on.

S5 Dip Switch Setting	Upper or Lower Float Switch Control
No. 1	
OFF	Lower Float Switch Control
ON	Upper Float Switch Control (this setting is ignored if refill counter (S5 dip switch 2 and 3) set to 0)

### 10. Refill Counter (S5 dip switch 2 and 3)

The refill counter determines the number of refills. The KMS-1122MLJ does not refill during the freeze cycle.

<b>NOTICE</b>
Do not adjust. These must be left in the factory default position or the icemaker will not operate correctly.

S5 Dip Switch Setting		Refill Counter
No. 2	No. 3	
OFF	OFF	0
OFF	ON	1 refill
ON	OFF	9 refills
ON	ON	10 refills

### 11. Minimum Harvest Time (S5 dip switch 4)

<b>NOTICE</b>
Factory set for proper operation. Do not adjust. Adjustment outside the factory default setting may result in damage to the appliance.

S5 Dip Switch Setting	Minimum Harvest Timer
No. 4	
OFF	120 sec.
ON	70 sec.

### 12. Anti-Slush (S5 dip switch 5)

This dip switch setting provides anti-slush control during the freeze cycle. When the evaporator temperature reaches 36°F (2.2°C) the control board reads a 5.8kΩ signal from the thermistor and de-energizes the water pump for 10 sec. to melt ice slush and prevent ice slush from blocking the water supply tubing, causing irregular freeze patterns.

<b>NOTICE</b>
Factory set for proper operation. Do not adjust. Adjustment outside the factory default setting may adversely affect performance and warranty coverage.

S5 Dip Switch Setting	Anti-Slush
No. 5	
OFF	Disabled
ON	Enabled

## IV. Refrigeration Circuit and Component Service Information

### **⚠ WARNING**

- This appliance should be diagnosed and repaired only by qualified service personnel to reduce the risk of death, electric shock, serious injury, or fire.
- Before servicing the KMS or SRK: Move the KMS control switch to the "OFF" position and turn off the power supply to the SRK condensing unit. Place the KMS disconnect (if applicable) in the "OFF" position. Lockout/Tagout to prevent the power supply from being turned back on inadvertently.
- **CHOKING HAZARD:** Ensure all components, fasteners, and thumbscrews are securely in place after the icemaker is serviced. Make sure that none have fallen into the dispenser unit/ice storage bin.
- Make sure all food zones in the icemaker and dispenser unit/ice storage bin are clean after service.

### A. Refrigeration Circuit Service Information

#### **⚠ WARNING**

- Repairs requiring the refrigeration circuit to be opened must be performed by properly trained and EPA-certified service personnel.
- Use an electronic leak detector or soap bubbles to check for leaks. Add a trace of refrigerant to the system (if using an electronic leak detector), and then raise the pressure using nitrogen gas (140 PSIG). Do not use R-404A as a mixture with pressurized air for leak testing.

#### **NOTICE**

- Always recover the refrigerant and store it in an approved container. Do not discharge the refrigerant into the atmosphere.
- Do not leave the system open for longer than 15 min. when replacing or servicing parts. The Polyol Ester (POE) oils used in R-404A applications can absorb moisture quickly. Therefore it is important to prevent moisture from entering the system when replacing or servicing parts.
- Always install a new drier every time the sealed refrigeration system is opened. Do not replace the drier until after all other repair or replacement has been made. Install the new drier with the arrow on the drier in the direction of the refrigerant flow.
- When brazing, protect the drier by using a wet cloth to prevent the drier from overheating. Do not allow the drier to exceed 250°F (121°C).

#### 1. Refrigerant Recovery

The condensing unit and icemaker are provided with refrigerant shutoff valves. Using proper refrigerant practices, recover the refrigerant. Recovery via the condensing unit's refrigerant shutoff valves is recommended. Store the refrigerant in an approved container. Do not discharge the refrigerant into the atmosphere.

## 2. Brazing

### **⚠ WARNING**

- R-404A itself is not flammable at atmospheric pressure and temperatures up to 176°F (80°C).
- R-404A itself is not explosive or poisonous. However, when exposed to high temperatures (open flames), R-404A can be decomposed to form hydrofluoric acid and carbonyl fluoride both of which are hazardous.
- Do not use silver alloy or copper alloy containing arsenic.

- 1) Braze all fittings while purging with nitrogen gas flowing at a pressure of 3 to 4 PSIG.  
Note: Because the pipes in the evaporator case are specially coated to resist corrosion, it is important to make connections outside the evaporator case when possible. If it is necessary to braze inside the evaporator case, use sandpaper to remove the coating from the brazing connections before unbrazing the components.

### **NOTICE**

- Always install a new drier every time the sealed refrigeration system is opened.
- Do not replace the drier until after all other repair or replacement has been made. Install the new drier with the arrow on the drier in the direction of the refrigerant flow.
- When brazing, protect the drier by using a wet cloth to prevent the drier from overheating. Do not allow the drier to exceed 250°F (121°C).

- 2) Use an electronic leak detector or soap bubbles to check for leaks. Add a trace of refrigerant to the system (if using an electronic leak detector), and then raise the pressure using nitrogen gas (140 PSIG). Do not use R-404A as a mixture with pressurized air for leak testing.

## 3. Evacuation and Recharge (R-404A)

The condensing unit and icemaker are provided with refrigerant shutoff valves. Evacuation and recharge via the condensing unit's refrigerant shutoff valves is recommended.

- 1) Attach a vacuum pump to the system. Be sure to connect the charging hoses to both high and low-side refrigerant shutoff valves.

### **IMPORTANT**

The vacuum level and vacuum pump may be the same as those for current refrigerants. However, the rubber hose and gauge manifold to be used for evacuation and refrigerant charge should be exclusively for POE oils.

- 2) Turn on the vacuum pump. Open the gauge manifold valves, then open the high and low-side refrigerant shutoff valves. Never allow the oil in the vacuum pump to flow backwards.

- 3) Allow the vacuum pump to pull down to a 29.9" Hg vacuum. Evacuating period depends on pump capacity.
- 4) Close the low-side valve and high-side valve on the gauge manifold.
- 5) Disconnect the gauge manifold hose from the vacuum pump and attach it to a refrigerant service cylinder. Remember to loosen the connection and purge the air from the hose. For the required refrigerant charge, see the nameplate on the condensing unit or the rating label inside the icemaker. Hoshizaki recommends only virgin refrigerant or reclaimed refrigerant which meets ARI Standard 700 (latest edition) be used.
- 6) A liquid charge is required when charging an R-404A system (to prevent fractionation). Place the service cylinder on the scales; if the service cylinder is not equipped with a dip tube, invert the service cylinder, then place it on the scales. Open the high-side valve on the gauge manifold.
- 7) Allow the system to charge with liquid until the proper charge weight is met.
- 8) If necessary, add any remaining charge to the system through the low-side.  
**NOTICE! To prevent compressor damage, use a throttling valve or liquid dispensing device to add the remaining liquid charge through the low-side refrigerant shutoff valve with the icemaker running.**
- 9) Close the high and low-side refrigerant shutoff valves. Close the high and low-side gauge manifold valves, then disconnect the gauge manifold hoses.
- 10) Cap the refrigerant shutoff valves to prevent a possible leak.

## B. Component Service Information

**NOTICE**

When replacing a component listed below, see the notes to help ensure proper operation.

Component	Notes
Compressor	1 Phase SRK: Install a new start capacitor, run capacitor, and start relay. 3 Phase SRK: Install a new magnetic contactor.
Thermostatic Expansion Valves	<ul style="list-style-type: none"> <li>• Attach the thermostatic expansion valve bulb to the suction line in the same location as the previous bulb.</li> <li>• The bulb should be between the 10 and 2 o'clock positions on the tube.</li> <li>• Secure the bulb with the clamp and holder, then insulate it.</li> </ul>
Hot Gas Valves Liquid Line Valves	<ul style="list-style-type: none"> <li>• Replace the strainer if applicable.</li> <li>• Use copper tube of the same diameter and length when replacing valve lines.</li> </ul>
Fan Motors	Install a new capacitor.
Pump Motor	Install a new capacitor.
Thermistor	<ul style="list-style-type: none"> <li>• Attach the new thermistor to the suction line in the same location as the previous thermistor.</li> <li>• The thermistor should be at the 12 o'clock position on the tube.</li> <li>• Smoothly fill the recessed area of the thermistor holder with high thermal conductive type sealant. Hoshizaki America part number 4A0683-01 (Silicone Heat Sink Compound 10-8108 manufactured by GC Electronics), KE-4560 RTV (manufactured by ShinEtsu Silicones), or equivalent are recommended.</li> <li>• Secure the thermistor with the holder, then insulate it.</li> <li>• Be very careful to prevent damage to the leads.</li> </ul>

## V. Maintenance

The maintenance schedule below is a guideline. More frequent maintenance may be required depending on water quality, the appliance's environment, and local sanitation regulations

### WARNING

- Only qualified service technicians should service the appliance.
- To reduce the risk of electric shock, do not touch the control switch or service switch with damp hands
- Before servicing the KMS or SRK: Move the KMS control switch to the "OFF" position and turn off the power supply to the SRK condensing unit. Place the KMS disconnect (if applicable) in the "OFF" position. Lockout/Tagout to prevent the power supply from being turned back on inadvertently.
- **CHOKING HAZARD:** Ensure all components, fasteners, and thumbscrews are securely in place after any maintenance is done to the icemaker. Make sure that none have fallen into the dispenser unit/ice storage bin.

### Maintenance Schedule

Frequency	Area	Task
Daily	Scoop	Clean the ice scoop using a neutral cleaner. Rinse thoroughly after cleaning.
Monthly	External Water Filters	Check for proper pressure and change if necessary.
	Icemaker Exterior	Wipe down with a clean, soft cloth. Use a damp cloth containing a neutral cleaner to wipe off oil or dirt build up. Clean any chlorine staining (rust colored spots) using a non-abrasive cleanser.
Yearly	Icemaker and Dispenser Unit/Ice Storage Bin Liner	Clean and sanitize per the cleaning and sanitizing instructions provided in the instruction manual or maintenance label on the icemaker.
	Water Supply Inlet	Close the icemaker water supply line shut-off valve and drain the water system. Clean the water supply inlet screen.
	Condenser	Inspect. Clean if necessary by using a brush or vacuum cleaner. More frequent cleaning may be required depending on location.
	Water Hoses	Inspect the water hoses and clean/replace if necessary.



---

## VI. Preparing the Appliance for Periods of Non-Use

<b>NOTICE</b>
<ul style="list-style-type: none"><li>• When storing the appliance for an extended time or in sub-freezing temperatures, follow the instructions below to prevent damage.</li><li>• To prevent damage to the water pump, do not operate the appliance with the control switch in the "SERVICE" position when the water tank is empty.</li></ul>



When the appliance is not used for two or three days under normal conditions, it is sufficient to move the control switch to the "OFF" position. When storing the appliance for an extended time or in sub-freezing temperatures, follow the instructions below.

### 1. Remove the water from the icemaker water line:

- 1) Turn off the power supply, then remove the front panel.
- 2) Close the icemaker water supply line shut-off valve and open the icemaker water supply line drain valve.
- 3) Allow the line to drain by gravity.
- 4) Attach a compressed air or carbon dioxide supply to the icemaker water supply line drain valve.
- 5) Make sure at least 3 min. have elapsed since you turned off the power supply. Make sure the control switch is in the "ICE" position. Replace the front panel in its correct position, then turn on the power supply.
- 6) Blow the icemaker water supply line out using the compressed air or carbon dioxide supply.
- 7) Close the icemaker water supply line drain valve.

### 2. Remove the water from the water tank:

- 1) Turn off the power supply.
- 2) Remove the front, apron, top, left side, and side insulation panels.
- 3) Move the control switch to the "OFF" position.
- 4) Remove the drain plug. Allow the water tank to drain.
- 5) Replace the drain plug in its correct position. Be careful not to cross thread the drain plug.
- 6) Replace the side insulation, left side, top, apron, and front panels in their correct positions.
- 7) Remove all ice from the dispenser unit/ice storage bin. Clean the dispenser unit/ice storage bin using a neutral cleaner. Rinse thoroughly after cleaning.

---

## **VII. Disposal**

The appliance contains refrigerant and must be disposed of in accordance with applicable national, state, and local codes and regulations. Refrigerant must be recovered by properly certified service personnel.

## VIII. Technical Information

We reserve the right to make changes in specifications and design without prior notice.

### A. Specification and Performance Data Sheets

Pressure data is recorded at 5 min. into freezing cycle. The data not in bold should be used for reference only.

#### 1. KMS-1122MLJ with SRK-12J

##### Specification Sheet

AC SUPPLY VOLTAGE	115VAC Supplied by SRK-12J via Factory Supplied Wire Harness	
ELECTRIC & WATER CONSUMPTION	90/70°F	70/50°F
ELECTRIC W (kWH/100 lbs.)	1880 (4.20)	1750 (3.64)
WATER gal./24HR (gal./100 lbs.)	172 (16.0)	335 (29.1)
ICE PRODUCTION PER CYCLE	18.6 lbs. (8.4 kg) 880pcs.	
BIN CONTROL SYSTEM	Thermostatic	
REFRIGERANT CHARGE	TOTAL R404A, 16 lb. 5 oz. (7400g) ICEMAKER, 0 lb. 7.1 oz. (200g) CONDENSER, 15 lb. 14 oz. (7200g)	

##### Performance Data Sheet

APPROXIMATE ICE PRODUCTION PER 24 HR.	AMBIENT TEMP. (°F/°C)	WATER TEMP. (°F/°C)					
		50/10		70/21		90/32	
	70/21	<b>1151</b>	<u>522</u>	1129	<u>512</u>	1138	<u>516</u>
	80/27	1134	<u>515</u>	1100	<u>499</u>	1131	<u>513</u>
	90/32	1129	<u>512</u>	<b>1075</b>	<u>488</u>	1097	<u>498</u>
lbs./day kg./day	100/38	1144	<u>519</u>	1080	<u>490</u>	1117	<u>507</u>
APPROXIMATE ELECTRIC CONSUMPTION	70/21	<b>1750</b>		1788		2065	
	80/27	1779		1838		2240	
	90/32	1788		<b>1880</b>		2234	
watts	100/38	1919		1963		2560	
APPROXIMATE WATER CONSUMPTION PER 24 HR.	70/21	<b>335</b>	<u>1.27</u>	287	<u>1.09</u>	274	<u>1.04</u>
	80/27	298	<u>1.13</u>	224	<u>0.85</u>	240	<u>0.91</u>
	90/32	287	<u>1.09</u>	<b>172</b>	<u>0.65</u>	176	<u>0.66</u>
gal./day m <sup>3</sup> /day	100/38	237	<u>0.90</u>	173	<u>0.65</u>	179	<u>0.68</u>
FREEZING CYCLE TIME	70/21	<b>19</b>		19		21	
	80/27	19		21		23	
	90/32	19		<b>22</b>		24	
min.	100/38	20		22		26	
HARVEST CYCLE TIME	70/21	<b>5.0</b>		4.4		3.9	
	80/27	4.5		3.5		3.2	
	90/32	4.4		<b>2.7</b>		2.4	
min.	100/38	3.5		2.6		2.0	
HEAD PRESSURE	70/21	<b>175</b>	<u>12.3</u>	191	<u>13.5</u>	212	<u>14.9</u>
	80/27	188	<u>13.2</u>	213	<u>15.0</u>	232	<u>16.3</u>
	90/32	191	<u>13.5</u>	<b>231</b>	<u>16.2</u>	251	<u>17.7</u>
PSIG kg/cm <sup>2</sup> G	100/38	195	<u>13.7</u>	236	<u>16.6</u>	270	<u>19.0</u>
SUCTION PRESSURE	70/21	<b>40</b>	<u>2.8</u>	41	<u>2.9</u>	48	<u>3.4</u>
	80/27	41	<u>2.9</u>	43	<u>3.0</u>	52	<u>3.7</u>
	90/32	41	<u>2.9</u>	<b>44</b>	<u>3.1</u>	52	<u>3.7</u>
PSIG kg/cm <sup>2</sup> G	100/38	44	<u>3.1</u>	46	<u>3.2</u>	60	<u>4.2</u>
TOTAL HEAT OF REJECTION FROM CONDENSER	16,500 BTU/h [AT 90°F (32°C) / WT 70°F (21°C)]						
TOTAL HEAT OF REJECTION FROM COMPRESSOR	2,300 BTU/h [AT 90°F (32°C) / WT 70°F (21°C)]						
CONDENSER VOLUME	226 CU. IN. (SRK12J)						

## 2. KMS-1122MLJ with SRK-12J3

### Specification Sheet

AC SUPPLY VOLTAGE	115VAC Supplied by SRK-12J3 via Factory Supplied Wire Harness	
ELECTRIC & WATER CONSUM	90/70°F	70/50°F
ELECTRIC W (kWH/100 lt)	1850 (4.05)	1730 (3.60)
WATER gal./24HR (gal./10C)	176 (16.0)	338 (29.3)
ICE PRODUCTION PER CYCL	18.6 lbs. (8.4 kg) 880pcs.	
BIN CONTROL SYSTEM	Thermostatic	
REFRIGERANT CHARGE	TOTAL R404A, 16 lb. 5 oz. (7400g)	
	ICEMAKER, 0 lb. 7.1 oz. (200g)	
	CONDENSER, 15 lb. 14 oz. (7200g)	

### Performance Data Sheet

APPROXIMATE ICE PRODUCTION PER 24 HR.	AMBIENT TEMP. (°F/°C)	WATER TEMP. (°F/°C)					
		50/10		70/21		90/32	
	70/21	<b>1151</b>	<u>522</u>	1136	<u>515</u>	1138	<u>516</u>
	80/27	1140	<u>517</u>	1116	<u>506</u>	1131	<u>513</u>
	90/32	1136	<u>515</u>	<b>1100</b>	<u>499</u>	1109	<u>503</u>
lbs./day <u>kg./day</u>	100/38	1144	<u>519</u>	1102	<u>500</u>	1117	<u>507</u>
APPROXIMATE ELECTRIC CONSUMPTION	70/21	<b>1730</b>		1765		1924	
	80/27	1757		1811		2032	
	90/32	1765		<b>1850</b>		2048	
watts	100/38	1834		1896		2230	
APPROXIMATE WATER CONSUMPTION PER 24 HR.	70/21	<b>338</b>	<u>1.28</u>	290	<u>1.10</u>	276	<u>1.04</u>
	80/27	302	<u>1.14</u>	228	<u>0.86</u>	242	<u>0.91</u>
	90/32	290	<u>1.10</u>	<b>176</b>	<u>0.66</u>	177	<u>0.67</u>
gal./day <u>m<sup>3</sup>/day</u>	100/38	240	<u>0.91</u>	176	<u>0.67</u>	179	<u>0.68</u>
FREEZING CYCLE TIME	70/21	<b>19</b>		19		22	
	80/27	19		21		23	
	90/32	19		<b>21</b>		24	
min.	100/38	20		22		26	
HARVEST CYCLE TIME	70/21	<b>5.1</b>		4.4		3.9	
	80/27	4.6		3.5		3.2	
	90/32	4.4		<b>2.8</b>		2.4	
min.	100/38	3.6		2.7		2.0	
HEAD PRESSURE	70/21	<b>179</b>	<u>12.6</u>	194	<u>13.6</u>	214	<u>15.1</u>
	80/27	190	<u>13.4</u>	214	<u>15.0</u>	234	<u>16.5</u>
	90/32	194	<u>13.6</u>	<b>230</b>	<u>16.2</u>	251	<u>17.6</u>
PSIG <u>kg/cm<sup>2</sup>G</u>	100/38	198	<u>13.9</u>	235	<u>16.5</u>	270	<u>19.0</u>
SUCTION PRESSURE	70/21	<b>42</b>	<u>3.0</u>	43	<u>3.0</u>	49	<u>3.4</u>
	80/27	43	<u>3.0</u>	45	<u>3.1</u>	53	<u>3.7</u>
	90/32	43	<u>3.0</u>	<b>46</b>	<u>3.2</u>	53	<u>3.7</u>
PSIG <u>kg/cm<sup>2</sup>G</u>	100/38	46	<u>3.2</u>	48	<u>3.4</u>	60	<u>4.2</u>
TOTAL HEAT OF REJECTION FROM CONDENSER	17,300 BTU/h [AT 90°F (32°C) / WT 70°F (21°C)]						
TOTAL HEAT OF REJECTION FROM COMPRESSOR	2,300 BTU/h [AT 90°F (32°C) / WT 70°F (21°C)]						
CONDENSER VOLUME	226 CU. IN. (SRK12J3)						

### 3. SRK-12J

#### Specification Sheet

AC SUPPLY VOLTAGE	208-230/60/1 ( 3 wire with neutral for 115V ) (115VAC Supplied to KMS via Factory Wire Harness)	
AMPERAGE	11.6 A ( 5 Min. Freeze AT 104°F / WT 80°F )	
MINIMUM CIRCUIT AMPACITY	20 A	
MAXIMUM FUSE SIZE	20 A	
EXTERIOR DIMENSIONS (WxDxH)	50-1/4" x 17" x 28" (1274 x 432 x 712 mm)	
DIMENSIONS INCLUDING LEGS (WxDxH)	50-1/4" x 17" x 43" (1274 x 432 x 1092 mm)	
EXTERIOR FINISH	Galvanized steel	
WEIGHT	Net 230 lbs. (104 kg), Shipping 275 lbs. (125 kg)	
CONNECTIONS - ELECTRIC	Main Power Supply: Permanent Connection SRK to KMS: Wire Harness Connection	
- REFRIGERATION	Suction line - 5/8" Brazed Connections	
CIRCUIT	Liquid line - 1/2" Brazed Connections	
COMPRESSOR	Hermetic, Model CS12K6E-PFV	
CONDENSER	Air Cooled, Fin and Tube Type	
COMPRESSOR PROTECTION	Auto-Reset Overload Protector (Internal)	
FAN MOTOR PROTECTION	Thermal Protection	
REFRIGERANT CIRCUIT PROTECTION	Auto-Reset High-Pressure Switch	
REFRIGERANT CONTROL	Condensing Pressure Regulator	
REFRIGERANT CHARGE	TOTAL R404A, 16 lb. 5 oz. (7400g) ICEMAKER, 0 lb. 7.1 oz. (200g) CONDENSER, 15 lb. 14 oz. (7200g)	
DESIGN PRESSURE	High 467 PSIG, Low 230 PSIG	
OPERATING CONDITIONS	VOLTAGE RANGE	187-253VAC
	AMBIENT TEMP. (Outdoor use)	-20-122°F
ACCESSORIES -SUPPLIED	Legs and hardware	
-REQUIRED	Compatible KMS icemaker Line set HS-0250, HS-0251, HS-0252	
TOTAL HEAT OF REJECTION FROM CONDENSER	16,500 BTU/h [AT 90°F (32°C) / WT 70°F (21°C)]	
TOTAL HEAT OF REJECTION FROM COMPRESSOR	2,300 BTU/h [AT 90°F (32°C) / WT 70°F (21°C)]	
CONDENSER VOLUME	226 CU. IN.	

## 4. SRK-12J3

### Specifications Sheet

AC SUPPLY VOLTAGE	208-230/60/3 (115VAC Supplied to KMS via Factory Wire Harness)	
AMPERAGE	10.5 A ( 5 Min. Freeze AT 104°F / WT 80°F )	
MINIMUM CIRCUIT AMPACITY	20 A	
MAXIMUM FUSE SIZE	20 A	
EXTERIOR DIMENSIONS (WxDxH)	50-1/4" x 17" x 28" (1274 x 432 x 712 mm)	
DIMENSIONS INCLUDING LEGS (WxDxH)	50-1/4" x 17" x 43" (1274 x 432 x 1092 mm)	
EXTERIOR FINISH	Galvanized steel	
WEIGHT	Net 230 lbs. (104 kg), Shipping 275 lbs. (125 kg)	
CONNECTIONS - ELECTRIC	Main Power Supply: Permanent Connection SRK to KMS: Wire Harness Connection	
- REFRIGERATION CIRCUIT	Suction line - 5/8" Brazed Connections Liquid line - 1/2" Brazed Connections	
COMPRESSOR	Hermetic, Model CS12K6E-TF5	
CONDENSER	Air Cooled, Fin and Tube Type	
COMPRESSOR PROTECTION	Auto-Reset Overload Protector (Internal)	
FAN MOTOR PROTECTION	Thermal Protection	
REFRIGERANT CIRCUIT PROTECTION	Auto-Reset High-Pressure Switch	
REFRIGERANT CONTROL	Condensing Pressure Regulator	
REFRIGERANT CHARGE	TOTAL R404A, 16 lb. 5 oz. (7400g) ICEMAKER, 0 lb. 7.1 oz. (200g) CONDENSER, 15 lb. 14 oz. (7200g)	
DESIGN PRESSURE	High 467 PSIG, Low 230 PSIG	
OPERATING CONDITIONS	VOLTAGE RANGE	187-253VAC
	AMBIENT TEMP. (Outdoor use)	-20-122°F
ACCESSORIES -SUPPLIED	Legs and hardware	
-REQUIRED	Compatible KMS icemaker Line set HS-0250, HS-0251, HS-0252	
TOTAL HEAT OF REJECTION FROM CONDENSER	17,300 BTU/h [AT 90°F (32°C) / WT 70°F (21°C)]	
TOTAL HEAT OF REJECTION FROM COMPRESSOR	2,300 BTU/h [AT 90°F (32°C) / WT 70°F (21°C)]	
CONDENSER VOLUME	226 CU. IN.	

## B. Wiring Diagrams

### 1. Wire Harness Connections

#### Wire Harness Connections

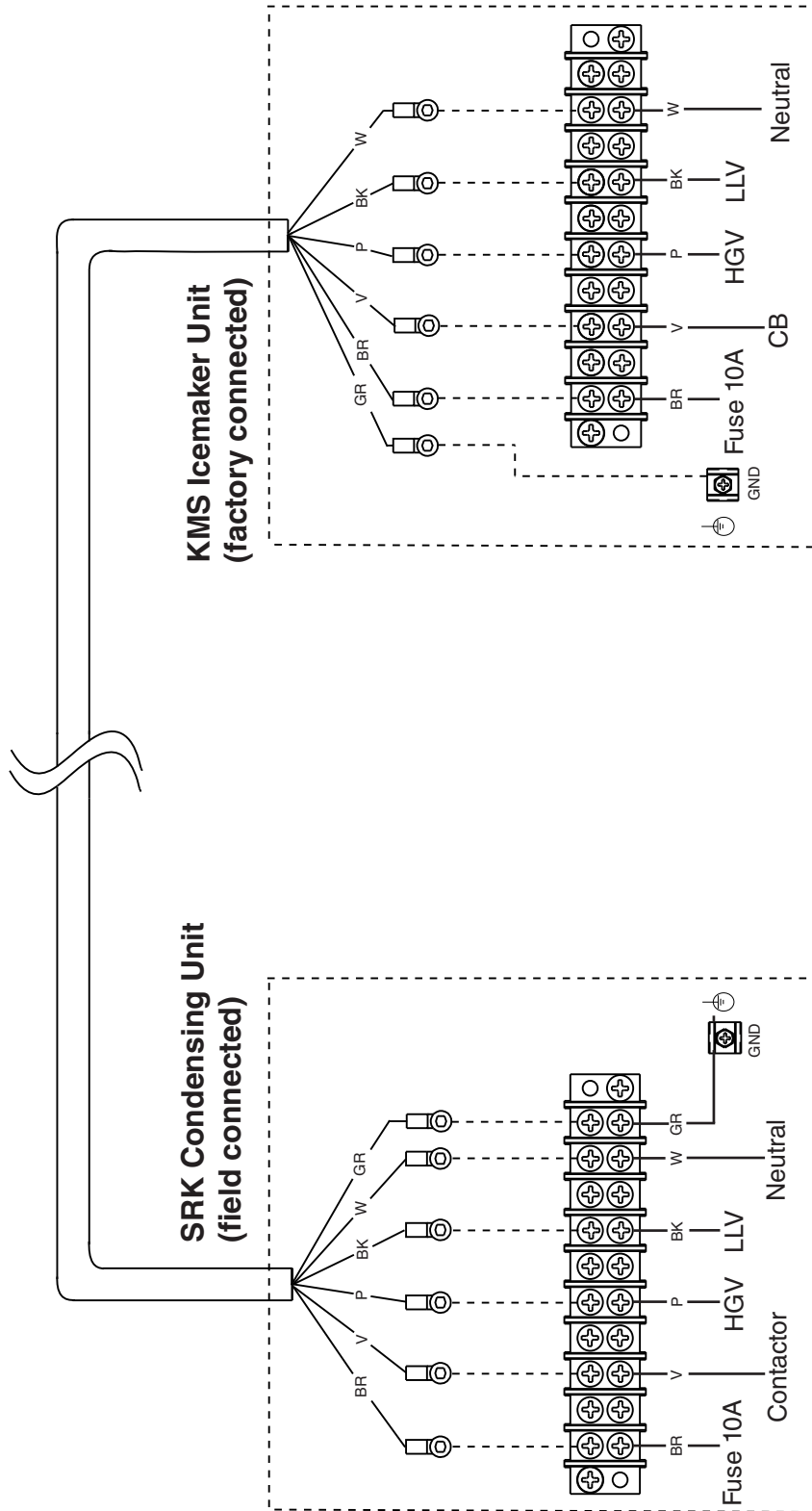

**Wire Color Code:**

- BK-black
- BR-brown
- GR-green
- P-pink
- V-violet
- W-white

**Legend:**

- CB-control board
- GND-ground
- HGV-hot gas valve
- LLV-liquid line valve

## 2. KMS-1122MLJ with SRK-12J

WIRE COLOR CODE  
 BK -BLACK  
 BR -BROWN  
 DBU -DARK BLUE  
 GR -GREEN  
 OY -GRAY  
 O -ORANGE  
 P -PINK  
 R -RED  
 V -VIOLET  
 W -WHITE  
 Y -YELLOW  
 W/BR -WHITE/BROWN  
 W/R -WHITE/RED  
 W/BK -WHITE/BLACK

S4 DIP SWITCH SETTING	No.1	No.2	No.3	No.4	No.5	No.6	No.7	No.8	No.9	No.10
KMS-1122MLJ	OFF	OFF	OFF	OFF	ON	OFF	ON	OFF	OFF	OFF

S5 DIP SWITCH SETTING	No.1	No.2	No.3	No.4	No.5
KMS-1122MLJ	OFF	OFF	OFF	OFF	ON

X10 PUMP MOTOR RELAY	OFF	ON
X11 X10 CONTROL RELAY	OFF	OFF
X12 PUMPOUT RELAY	OFF	ON

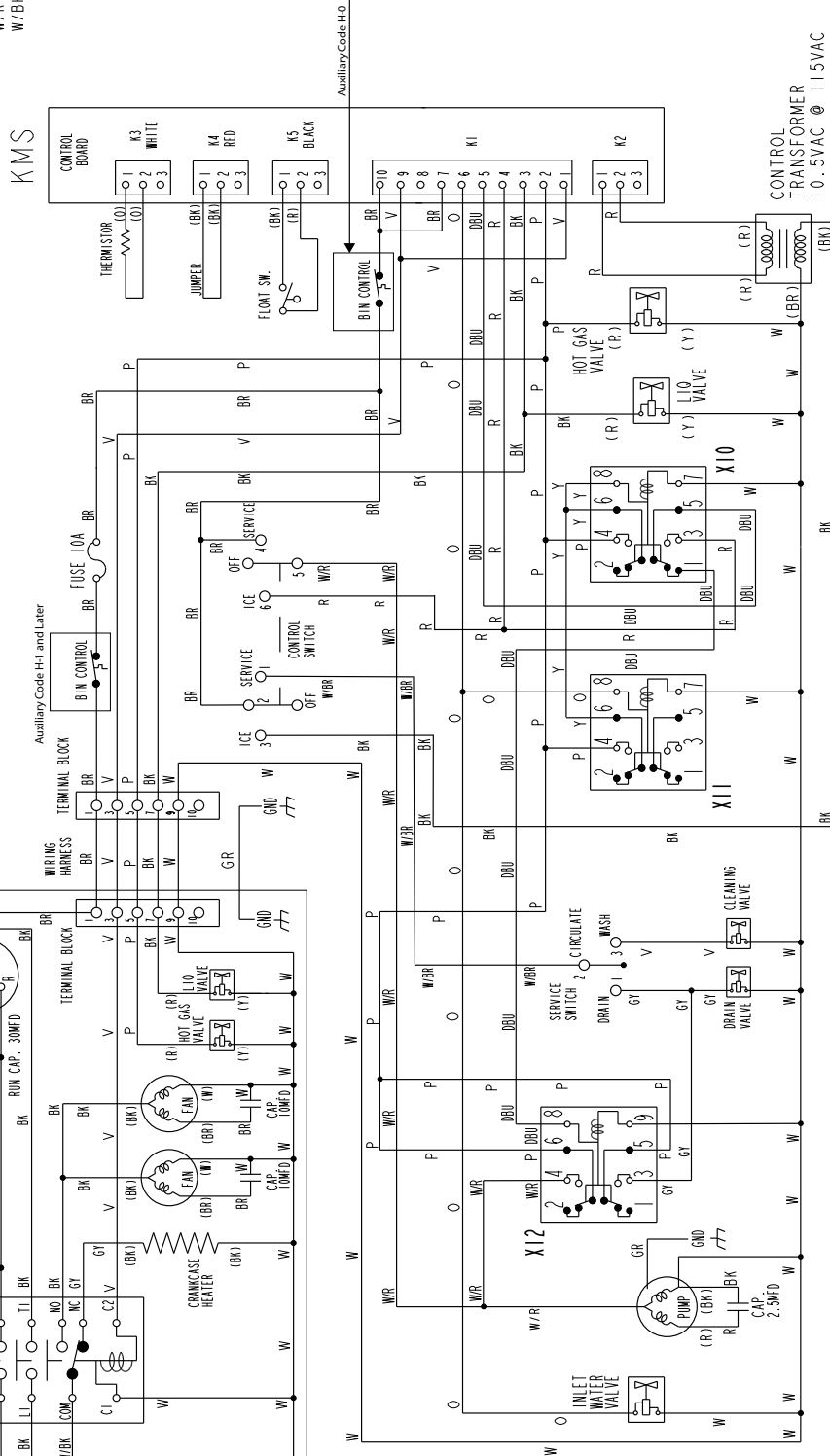
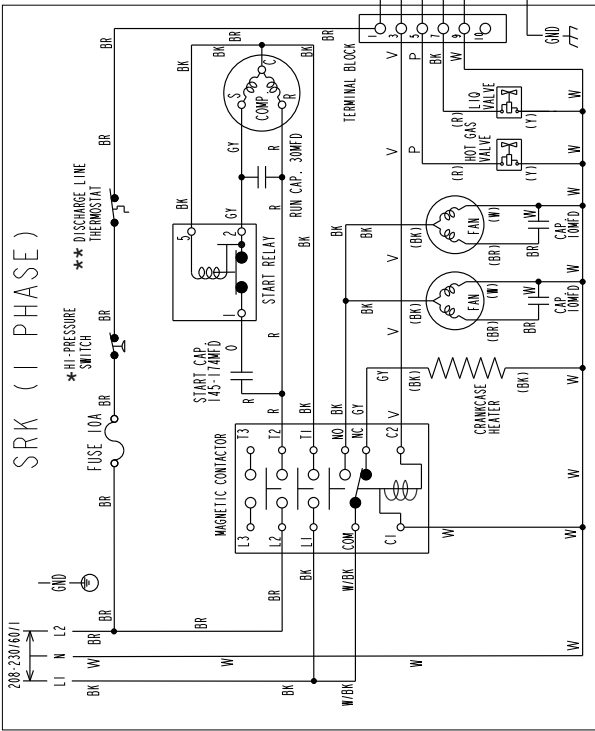

** Discharge Line Thermostat
Cut-out 266°F±9°F (130°C±5°C)
Cut-in 239°F±9°F (115°C±5°C)

*High-Pressure Switch
Cut-out 426±2 <sub>0</sub> PSIG
Cut-in 341±22 PSIG



### 3. KMS-1122MLJ with SRK-12J3

WIRE COLOR CODE

BK	-BLACK
BR	-BROWN
DBU	-DARK BLUE
GR	-GREEN
GY	-GRAY
O	-ORANGE
P	-PINK
R	-RED
V	-VIOLET
W	-WHITE
Y	-YELLOW
W/BR	-WHITE/BROWN
W/R	-WHITE/RED
W/BK	-WHITE/BLACK

S4 DIP SWITCH SETTING	No. 1	No. 2	No. 3	No. 4	No. 5	No. 6	No. 7	No. 8	No. 9	No. 10
KMS-1122MLJ	OFF	OFF	OFF	OFF	ON	OFF	ON	OFF	OFF	OFF

S5 DIP SWITCH SETTING	No. 1	No. 2	No. 3	No. 4	No. 5
KMS-1122MLJ	OFF	OFF	OFF	OFF	ON

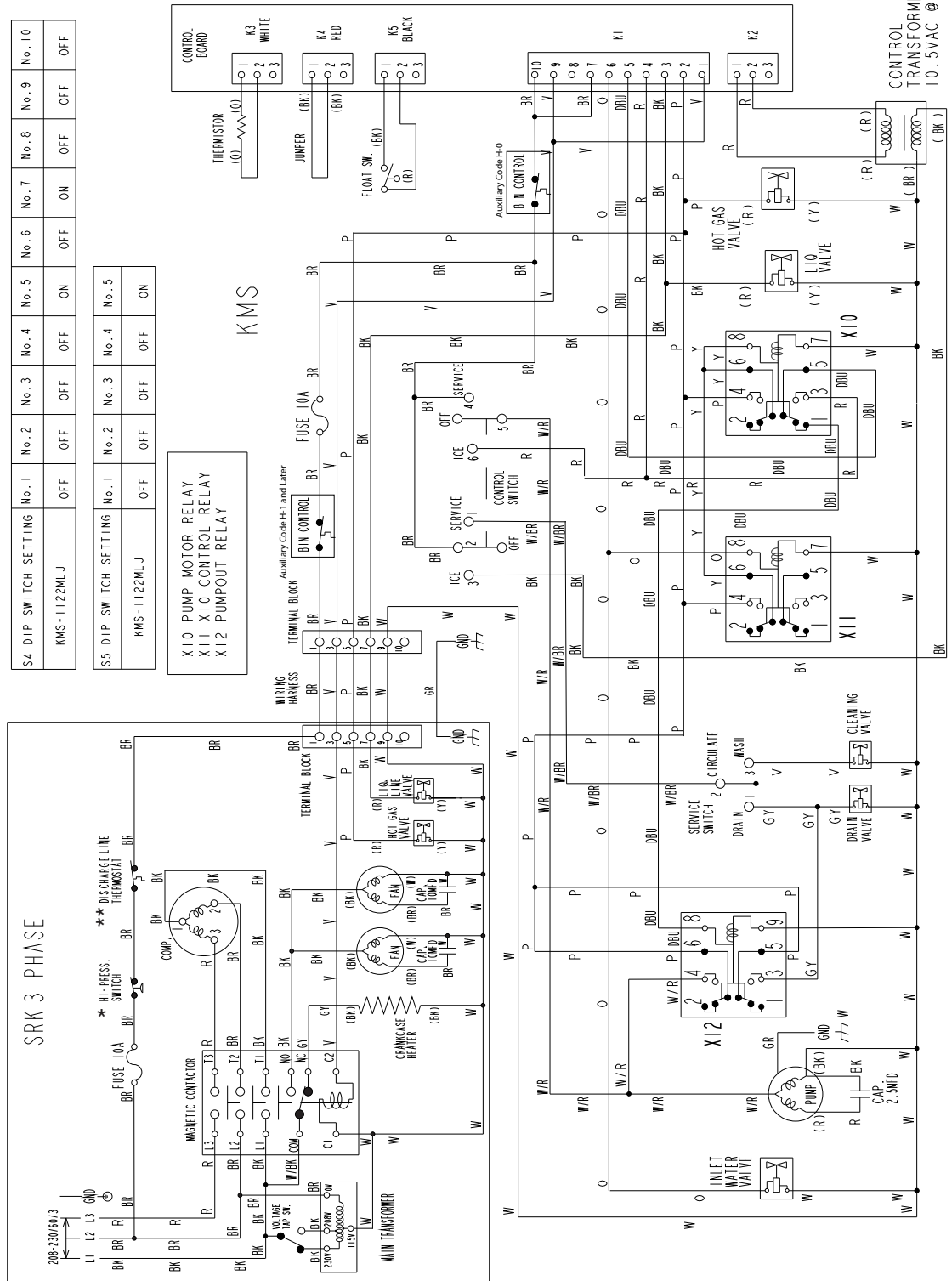

SRK 3 PHASE

KMS

** Discharge Line Thermostat	
Cut-out	266°F±9°F (130°C±5°C)
Cut-in	239°F±9°F (115°C±5°C)

*High-Pressure Switch	
Cut-out	426±22 PSIG
Cut-in	341±22 PSIG