

iT1200 Ice Cube Machine

Models

- IDT1200A
 IYT1200A
 IDT1200W
 IYT1200W
 IDT1200N
 IYT1200N



Indigo NXT iT1200 ice machine on a D570 bin

*Ice Machine and Bin sold separately

Designed for operators who know that ice is critical to their business, the Indigo NXT Series ice machine's preventative diagnostics continually monitor itself for reliable ice production. Improvements in cleanability and programmability make your ice machine easy to own and less expensive to operate.

- **New levels of Performance** – Showcasing an average of 5% lower energy consumption and a 22% reduction in condenser water usage. This translates into lower cost of ownership over the life of your machine.
- **easyTouch® Display** - New icon based touch screen takes the guess work out of owning and operating an ice machine.
- **Programmable Ice Production** – Now its super easy to program your ice machine to be off at certain times of the day to save money with fluctuating electrical rates. Also programmable by daily ice production volume and night time programming.
- **Easy to Clean Foodzone** – Hinge front door swing out for easy access. Removable water-trough, distribution tube, curtain, water probe and water pump for fast and efficient cleaning. Selected components are made with AlphaSan® antimicrobial.
- **Intelligent Diagnostics** – Provides 24 hour preventative maintenance and diagnostic feedback for trouble free operation.
- **Acoustical Ice Sensing Probe** – Unique patented technology allows for reliable operation in challenging water conditions and environments
- **DuraTech® Exterior** – Provides superior corrosion resistant above stainless steel. Innovative clear-coat resists fingerprints and dirt making it easier to keep clean.
- Available **LuminIce® II Growth Inhibitor** – Controls viruses, bacteria, mold and yeast within the food zone to keep the machine clean longer. A new sanitation icon lets you know the operational status.
- **Active Sense** – Insures consistent ice harvest in all environmental conditions. This software solution works in conjunction with the acoustical ice sensing probe improving reliability and performance.

Ice Machine Electric

208-230/60/1 standard
(208-230/60/3 also available)

Minimum circuit ampacity:

Air-cooled:	14.2 1ph	8.6 3ph
Water-cooled:	13.4 1ph	7.9 3ph
Remote:	11.0 1ph	9.2 3ph

Maximum fuse size:

Air-cooled:	20 1ph	15 3ph
Water-cooled:	20 1ph	15 3ph
Remote:	15 1ph	15 3ph

Specifications

BTU Per Hour:
16,200 (average),
and 19,100 (peak)

Refrigerant:

R410A CFS - Free
Lowers global warming
by 48%

Operating Limits:

- Ambient Temperature Range:
40 to 110 F (4.4 to 43.3 C)
Water Temperature Range:
40 to 90 F (4.4 to 32.2 C)
- Potable Water Pressure:
Min. 20 psi (137.9 kPa)
Max. 80 psi (551.1 kPa)
- Condenser Water Pressure:
Min. 20 psi (137.9 kPa)
Max. 276 psi (1902.95 kPa)



Ice Shape

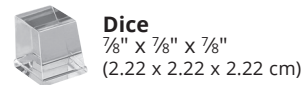
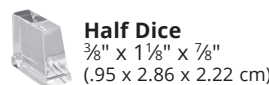



iT1200 on D-570 Storage Bin

- Ⓐ Electrical Entrance (2) Options
- Ⓑ 3/8" (0.95 cm) F.P.T. Water Condenser Inlet (water-cooled units)
- Ⓒ 1/2" (1.27 cm) F.P.T. Water Condenser Outlet (water-cooled units)
- Ⓓ 1/2" (1.27 cm) Auxillary Base Drain Socket
- Ⓔ 3/8" (0.95 cm) F.P.T. Ice Making Water Inlet
- Ⓕ 1/2" (1.27 cm) F.P.T. Ice Making Water Drain
- Ⓖ 3/4" (1.91 cm) Bin Drain

Installation Note
Minimum installation clearance:

Top/side: 8" (20.3cm)
Back is 5" (12.7 cm)

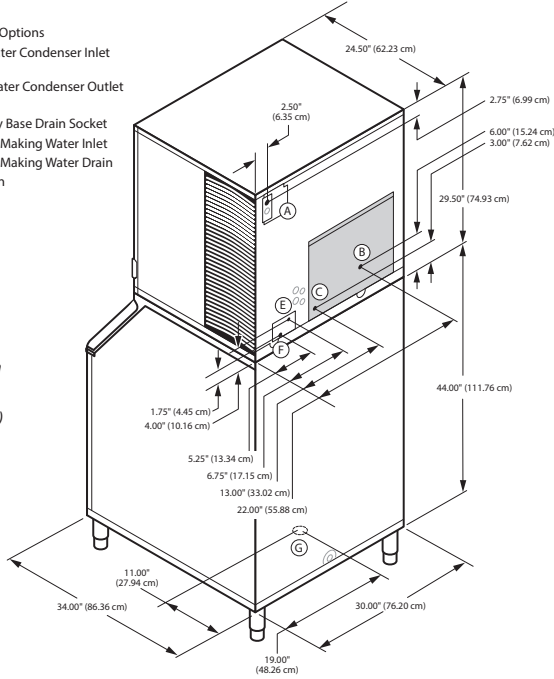

Space-Saving Design









	iT1200 D-570	iT1200 D-970
Height	79.50" 201.93 cm	79.50" 201.93 cm
Width	30.00" 76.20 cm	48.00" 121.92 cm
Depth	34.00" 86.30 cm	34.00" 86.30 cm
Bin	532 lbs.	882 lbs.
Storage	241.1 kgs.	400.1 kgs.

Height includes adjustable bin legs 6.00" to 8.00", (15.24 to 20.32 cm) set at 6.00" (15.24 cm).

Bin capacity is based on 90% of the volume x 33 lbs/ft3 average density of ice.

* **K00470 bin adapter** required when installing on a D970 Bin

Specifications

Model	Ice Shape	Ice Production 24 Hours				Power Usage kWh/100 lbs. @90°Air/70°F		Potable Water Usage/100 lbs. 45.4 kgs. of Ice
		70°Air/ 50°F Water		90°Air/ 70°F Water		1 Ph	3 Ph	
		1 ph	3 ph	1 ph	3 ph			
AIR COOLED	IDT1200A 	1196 lbs	n/a	950 lbs	n/a	4.80	n/a	19.9 Gal. 75.3 L
		542 kgs	n/a	431 kgs	n/a			
	IYT1200A 	1213 lbs	1203 lbs	950 lbs	940 lbs	4.75	4.83	19.9 Gal. 75.3 L
		550 kgs	546 kgs	431 kgs	426 kgs			
WATER COOLED	IDT1200W 	1078 lbs	n/a	900 lbs	n/a	4.16	n/a	19.9 Gal. 75.3 L
		498 kgs	n/a	408 kgs	n/a			
	IYT1200W 	1138 lbs	1220 lbs	965 lbs	1050 lbs	4.00	3.78	19.9 Gal. 75.3 L
		516 kg	553kgs	438 kgs	426 kgs			
* Water-cooled Condenser Water Usage / 100 lbs. /45.4 kgs. Of Ice: 140 gal/ 530 L. *Water-cooled models are excluded from ENERGY STAR qualification.								
REMOTE COOLED	IDT1200N 	1110 lbs	n.a.	925 lbs	n.a.	4.47	n/a	19.9 gal 75.3 L
		503 kgs	542 kgs	420 kgs	n.a.			
	IYT1200N 	1215 lbs	1215 lbs	1010 lbs	1010 lbs	4.20	4.20	19.9 gal 75.3 L
1010 kgs		551 kgs	458 kgs	458 kgs				

Order Separately ice storage bin for all units, JCT1200-A-vertical condenser order separately for Remote cooled units

Accessories

LuminIce® II Virus and Bacteria Inhibitor

controls viruses and bacteria inside the ice machine



External Scoop holder

Protect the ice scoop with the NSF approved versatile scoop holder.



Arctic Pure® Plus

reduce sediments and chlorine contaminants down to .5 microns. Use with Pre-filter recommended



iAuCS® schedules and performs routine ice machine cleaning automatically.



Manitowoc Ice reserves the right to make changes to the design or specifications without prior notice.