



KM-1301S_J(3)

STACKABLE ICE CUBER





KM-1301S_J(3)
07/08/19
Item # 13056

Item #: _____
Project: _____
Qty: _____
AIA#: _____

Features

- ▶ Individual crescent cube
- ▶ Stainless steel evaporator
- ▶ CycleSaver™ design 

- Up to 1433 lbs. of ice production per 24 hours
- Stackable for 2866 lbs. per 24 hours ice production in the same floor space
- Durable stainless steel exterior
- Protected by H-Guard Plus  Antimicrobial Agent
- EverCheck™ alert system 
- Removable air filters (Air-cooled model only)
- R-404A Refrigerant

Available on Bins:

B-800 **B-1150SS** **B-1500SS** *Top kit may be required.*
B-900 **B-1300SS** **B-1650SS** *See Bin Spec Sheets.*

Warranty:

3 Year Parts & Labor on entire machine. 5 Year Parts & Labor on Evaporator. 5 Year Parts on Compressor; air-cooled condenser coil. Valid in United States, Canada, Puerto Rico and U.S. Territories. Contact factory for warranty in other countries.

Shipping: (LxWxH) 51.75" x 33" X 33" Volume: 32.61ft³



W x D x H
48" x 27^{3/8}" x 27^{3/8}"

KM Edge DESIGN

KM-1301SAJ
Air-Cooled 1 Phase

KM-1301SWJ
Water-Cooled 1 Phase
Shown on optional bin B-900

KM-1301SRJ
Remote Air-Cooled 1 Phase

KM-1301SAJ3 ★
Air-Cooled 3 Phase

KM-1301SWJ3
Water-Cooled 3 Phase

KM-1301SRJ3 ★
Remote Air-Cooled 3 Phase



Condenser	Model	ICE PRODUCTION		WATER USAGE			ELECTRICAL				Heat Rejection BTU/hr.	Refrigerant Charge Amount	Net / Ship Weight (lbs.)
		Air / Water Temp 70°/50°F	90°/70°F	Potable Gal. per 100 lbs. 90°/70°F	Condenser Gal. per 100 lbs. 90°/70°F	kWh Used per 100 lbs. 90°/70°F	Max. Fuse Size or HACR Circuit Breaker	Amperage	Voltage	Circuit Wires (including ground)			
1 Phase	Air KM-1301SAJ	1365	1301	21.0	N/A	4.27	20A	12.4A	208-230V/60/1	3	19,400	3 lbs. 15.5 oz.	298 / 338
	Water KM-1301SWJ	1247	1230	21.0	89	3.76	20A	8.2A	208-230V/60/1	3	20,900	2 lbs. 2.4 oz.	295 / 335
	Remote KM-1301SRJ	1400	1260	14.0	N/A	4.28	20A	13.5A	208-230V/60/1	3	18,900	5 lbs. 15.2 oz. 10 lbs. 5.8 oz. ¹	299 / 339
3 Phase	Air KM-1301SAJ3	1427	1350	15.6	N/A	3.95	20A	9.5A	208-230V/60/3	4	18,400	4 lbs. 3 oz.	298 / 338
	Water KM-1301SWJ3	1360	1355	16.0	95	3.25	20A	6.1A	208-230V/60/3	4	20,100	2 lbs. 2.4 oz.	295 / 335
	Remote KM-1301SRJ3	1433	1330	14.0	N/A	3.83	20A	10.7A	208-230V/60/3	4	18,800	5 lbs. 15.2 oz. 10 lbs. 5.8 oz. ¹	299 / 339

¹with condenser

Power cord not included

KM Edge Cube Dimensions*

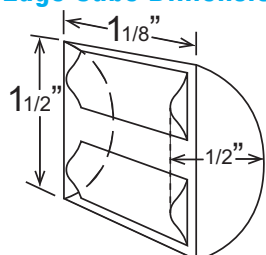

* approximate size in inches, image not to scale

Operating Limits

- Ambient Temp Range 45 - 100°F
- Water Temp Range 45 - 90°F
- Water Pressure 10 - 113 PSIG
- Voltage Range 187 - 253V

Service

- Panels easily removed and all components accessible for service.
- Allow 6" (15cm) clearance at rear, sides, and top for proper air circulation and ease of maintenance/service.

Plumbing

- Icemaker Water Supply Line: Min. 3/8" Nominal ID Copper Water Tubing or Equivalent
- Icemaker Drain Line: Min. 3/4" Nominal ID Hard Pipe or Equivalent
- Water-Cooled Model (Lines Must Be Independent of Icemaker)
- Condenser Water Supply Line: Min. 3/8" Nominal ID Copper Water Tubing or Equivalent
- Condenser Drain/Return Line: Min. 3/8" Nominal ID Hard Pipe (open drain system) or Copper Water Tubing (closed loop system) or Equivalent

Water Filter

Please refer to water filter spec sheet for recommended configurations.

Hoshizaki reserves the right to change specifications without notice.



KM-1301S_J(3)

STACKABLE ICE CUBER



KM-3101S_J(3)
07/08/19
Item # 1356

FRONT VIEW

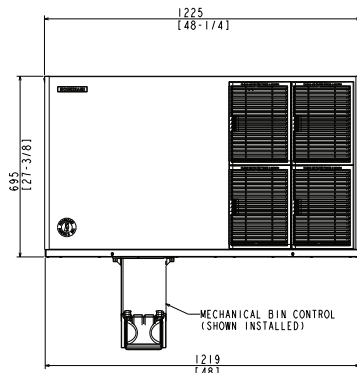

AIR-COOLED

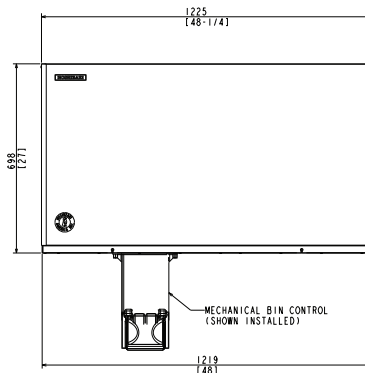

WATER-COOLED

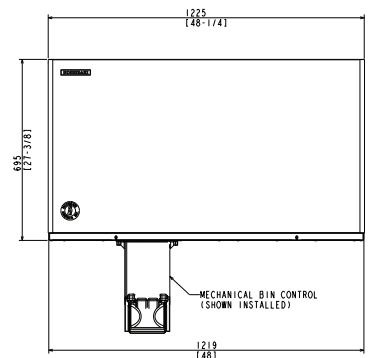

REMOTE AIR-COOLED

SIDE VIEW

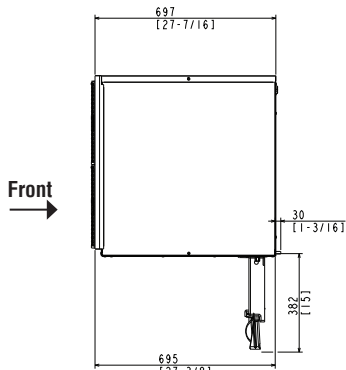

AIR-COOLED

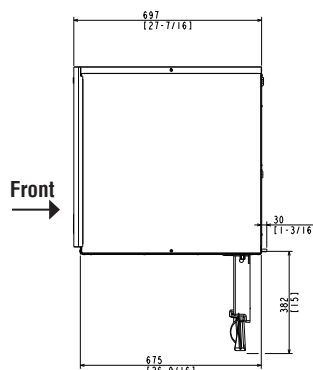

WATER-COOLED

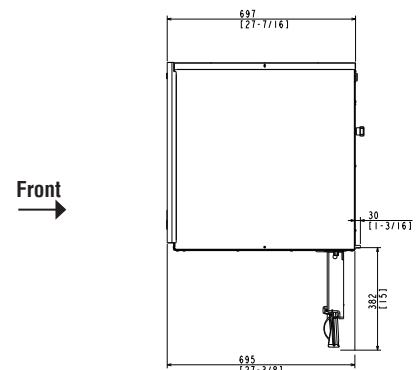

REMOTE AIR-COOLED

BACK VIEW

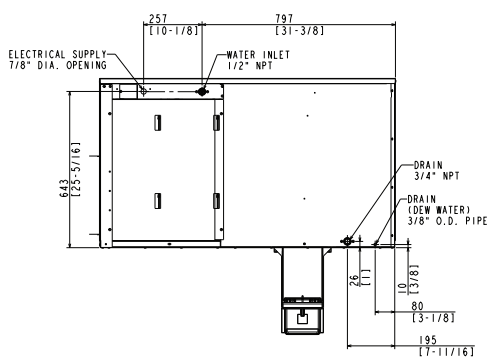

AIR-COOLED

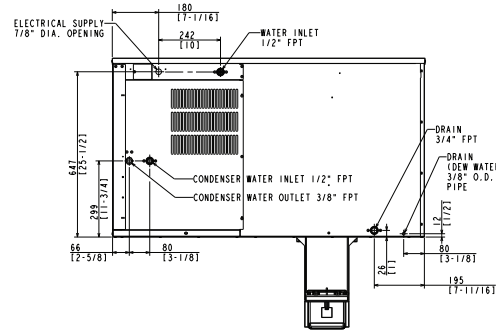

WATER-COOLED

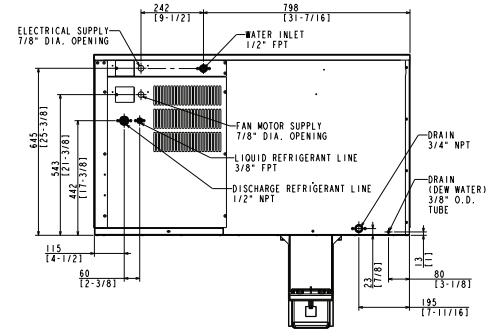

REMOTE AIR-COOLED

BOTTOM VIEW

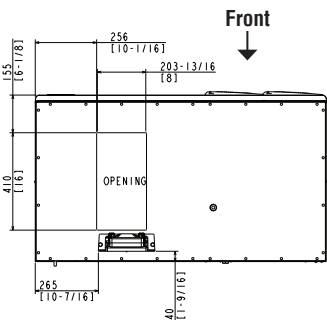

AIR-COOLED

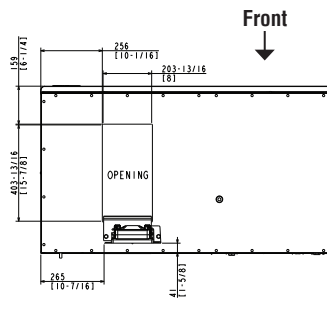

WATER-COOLED

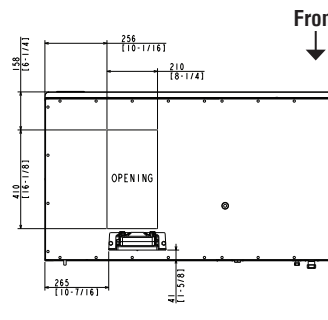

REMOTE AIR-COOLED

URC-14F Remote Condenser (Sold Separately)
For Use with KM-1301SRJ(3)

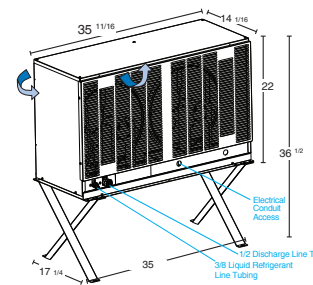

Pre-Charged Tubing Kits
(Sold Separately)
20' R404-2068-2
35' R404-3568-2
55' R404-5568-2



Voltage supply for the URC Remote Condenser is supplied from the Ice Maker. No additional circuit is required.